

Approved for use through 10/31/2002. OMB 0651-0031  
U.S. Patent and Trademark Office; U.S. DEPARTMENT OF COMMERCE

Under the Paperwork Reduction Act of 1995, no persons are required to respond to a collection of information unless it displays a valid OMB control number.

**NOTICE OF APPEAL FROM THE EXAMINER TO THE BOARD OF PATENT APPEALS AND INTERFERENCES.**

Docket Number (Optional)  
600456-0023 B64418C

**RECEIVED**

FEB 12 2003

Technology Center 2600

I hereby certify that this correspondence is being deposited with the United States Postal Service with sufficient postage as first class mail in an envelope addressed to "Assistant Commissioner for Patents, Washington D.C. 20231" on 02/05/2003

Signature \_\_\_\_\_  
Typed or printed name Kelly Breeze

In re Application of  
Underbrink, et al.

Application Number 09/394,189 Filed 09/13/1999

For Directional Antenna for Hand-Held Wireless Communications Device

Group Art Unit 2685 Examiner Craver, Charles R.

Applicant hereby **appeals** to the Board of Patent Appeals and Interferences from the last decision of the examiner.

The fee for this Notice of Appeal is (37 CFR 1.17(b)) \$ 320.00

- Applicant claims small entity status. See 37 CFR 1.27. Therefore, the fee shown above is reduced by half, and the resulting fee is: \$ \_\_\_\_\_
- A check in the amount of the fee is enclosed.
- Payment by credit card. Form PTO-2038 is attached.
- The Commissioner has already been authorized to charge fees in this application to a Deposit Account. I have enclosed a duplicate copy of this sheet.
- The Commissioner is hereby authorized to charge any fees which may be required, or credit any overpayment to Deposit Account No. 01-0657. I have enclosed a duplicate copy of this sheet.
- A petition for an extension of time under 37 CFR 1.136(a) (PTO/SB/22) is enclosed.

**WARNING: Information on this form may become public. Credit card information should not be included on this form. Provide credit card information and authorization on PTO-2038.**

- I am the
- applicant/inventor.
  - assignee of record of the entire interest. See 37 CFR 3.71. Statement under 37 CFR 3.73(b) is enclosed. (Form PTO/SB/96)
  - attorney or agent of record.
  - attorney or agent acting under 37 CFR 1.34(a).  
Registration number if acting under 37 CFR 1.34(a) \_\_\_\_\_

\_\_\_\_\_  
Signature  
Reg. No. 39,348

Christopher J. Rourk  
\_\_\_\_\_  
Typed or printed name  
02/05/2003  
\_\_\_\_\_  
Date

NOTE: Signatures of all the inventors or assignees of record of the entire interest or their representative(s) are required. Submit multiple forms if more than one signature is required, see below\*.

\*Total of 1 forms are submitted.

Burden Hour Statement: This form is estimated to take 0.2 hours to complete. Time will vary depending upon the needs of the individual case. Any comments on the amount of time you are required to complete this form should be sent to the Chief Information Officer, U.S. Patent and Trademark Office, Washington, DC 20231. DO NOT SEND FEES OR COMPLETED FORMS TO THIS ADDRESS. SEND TO: Assistant Commissioner for Patents, Washington, DC 20231.

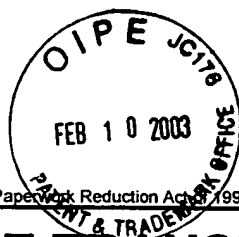

Approved for use through 10/31/2002. OMB 0651-0032  
 U.S. Patent and Trademark Office; U.S. DEPARTMENT OF COMMERCE  
 Under the Paperwork Reduction Act of 1995, no persons are required to respond to a collection of information unless it displays a valid OMB control number.

<h1 style="margin: 0;">FEE TRANSMITTAL</h1> <h2 style="margin: 0;">for FY 2003</h2> <p style="margin: 5px 0 0 20px;">Patent fee are subject to annual revision.</p>	<b>Complete if Known</b>	
	Application Number	09/394,189
	Filing Date	September 13, 1999
	First Named Inventor	Paul A. Underbrink
	Examiner Name	Charles Craver
Group Art Unit	2685	
Attorney Docket No.	600456/0023 (B64418C)	
<b>TOTAL AMOUNT OF PAYMENT</b>		<b>(\$)</b> 320.00

**METHOD OF PAYMENT**

1.  The Commissioner is hereby authorized to charge indicated fees and credit any overpayments to:

Deposit Account Number: 01-0657

Deposit Account Name: Akin Gump Deposit Account

Charge Any Additional Fee Required Under 37 CFR 1.16 and 1.17

Applicant claims small entity status. See 37 CFR 1.27

2.  Payment Enclosed:

Check    Credit Card    Money Order    Other

**FEE CALCULATION (continued)**

**3. ADDITIONAL FEES**

Fee Code	Large Entity Fee (\$)	Small Entity Fee (\$)	Fee Description	Fee Paid	
1051	130	2051	65	Surcharge - late filing fee or oath	
1052	50	2052	25	Surcharge - late provisional filing fee or cover sheet	
1053	130	1053	130	Non-English specification	
1812	2,520	1812	2,520	For filing a request for ex parte reexamination	
1804	920*	1804	920*	Requesting publication of SIR prior to Examiner action	
1805	1,840*	1805	1,840*	Requesting publication of SIR after Examiner action	
1251	110	2251	55	Extension for reply within first month	
1252	410	2252	205	Extension for reply within second month	
1253	930	2253	465	Extension for reply within third month	
1254	1,450	2254	725	Extension for reply within fourth month	
1255	1,970	2255	985	Extension for reply within fifth month	
1401	320	2401	160	Notice of Appeal	
1402	320	2402	160	Filing a brief in support of an appeal	320.00
1403	280	2403	140	Request for oral hearing	
1451	1,510	1451	1,510	Petition to institute a public use proceeding	
1452	110	2452	55	Petition to revive - unavoidable	
1453	1,300	2453	650	Petition to revive - unintentional	
1501	1,300	2501	650	Utility issue fee (or reissue)	
1502	470	2502	235	Design issue fee	
1503	630	2503	315	Plant issue fee	
1460	130	1460	130	Petitions to the Commissioner	
1807	50	1807	50	Processing fee under 37 CFR 1.17(q)	
1806	180	1806	180	Submission of information Disclosure Stmt	
8021	40	8021	40	Recording each patent assignment per property (times number of properties)	
1809	750	2809	375	Filing a submission after final rejection (37 CFR § 1.129(a))	
1810	750	2810	375	For each additional invention to be examined (37 CFR § 1.129(b))	
1801	750	2801	375	Request for Continued Examination (RCE)	
1802	900	1802	900	Request for expedited examination of a design application	
Other fee (specify)					
<b>SubTOTAL (3)</b>				<b>(\$)</b> 320.00	

**FEE CALCULATION**

**1. BASIC FILING FEE**

Large Entity Fee Code	Large Entity Fee (\$)	Small Entity Fee Code	Small Entity Fee (\$)	Fee Description	Fee Paid
1001	750	2001	375	Utility filing fee	
1002	330	2002	165	Design filing fee	
1003	520	2003	260	Plant filing fee	
1004	750	2004	375	Reissue filing fee	
1005	160	2005	80	Provisional filing fee	
<b>SUBTOTAL (1)</b>					<b>(\$)</b>

**2. EXTRA CLAIM FEES**

Total Claims: 19 - 20\*\* = 0 X \$18.00 = \$ .00

Independent Claims: 4 - 4\*\* = 0 X \$84.00 = \$ .00

Multiple Dependent: -0- = -0-

Large Entity Fee Code	Large Entity Fee (\$)	Small Entity Fee Code	Small Entity Fee (\$)	Fee Description	Fee Paid
1202	18	2202	9	Claims in excess of 20	
1001	84	2201	42	Independent claims in excess of 3	
1203	280	2203	140	Multiple dependent claim, if not paid	
1204	84	2204	42	**Reissue independent claims over original patent	
1205	18	2205	9	**Reissue claims in excess of 20 and over original patent	
<b>SUBTOTAL (2)</b>					<b>(\$)</b> .00

<b>SUBMITTED BY</b>		<b>Complete (if applicable)</b>			
Name (Print/Type)	Christopher J. Rourk	Registration No. (Attorney/Agent)	39,348	Telephone	214-969-4669
Signature		Date	February 5, 2003		

**WARNING: Information on this form may become public. Credit card information should not be included on this form. Provide credit card information and authorization on PTO-2038.**

Burden Hour Statement: This form is estimated to take 0.2 hours to complete. Time will vary depending upon the needs of the individual case. Any comments on the amount of time you are required to complete this form should be sent to the Chief Information Officer, U.S. Patent and Trademark Office, Washington, DC 20231. DO NOT SEND FEES OR COMPLETED FORMS TO THIS ADDRESS. SEND TO: Assistant Commissioner for Patents, Washington, DC 20231.

**IN THE UNITED STATES PATENT AND TRADEMARK OFFICE  
BEFORE THE BOARD OF PATENT APPEALS AND INTERFERENCES**

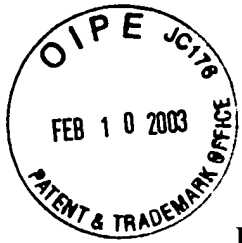

In re Appellant:

PAULA A. UNDERBRINK  
RICKE W. CLARK  
CHRISTIAN LEVESQUE  
GUANGMING YIN  
PATRICK D. RYAN

§  
§  
§  
§  
§  
§  
§  
§  
§  
§  
§  
§  
§  
§  
§  
§  
§

Confirmation No.: 3874

Filed: September 13, 1999

Art Unit: 2685

Serial No.: 09/394,189

Examiner: Charles Craver

For: DIRECTIONAL ANTENNA FOR  
HAND-HELD WIRELESS  
COMMUNICATIONS DEVICE

Docket No.: 600456-0023 (B64418C)

**APPEAL BRIEF**

Christopher J. Rourk  
AKIN GUMP STRAUSS HAUER  
& FELD LLP  
P.O. Box 688  
Dallas, Texas 75313-0688  
(214) 969-4669  
(214) 969-4343 Fax



## TABLE OF CONTENTS

	<u>PAGE</u>
I. REAL PARTY IN INTEREST .....	1
II. RELATED APPEALS AND INTERFERENCES.....	2
III. STATUS OF THE CLAIMS.....	2
IV. STATUS OF AMENDMENTS .....	2
V. SUMMARY OF THE INVENTION .....	2
VI. ISSUES ON APPEAL .....	3
VII. GROUPING OF THE CLAIMS .....	3
VIII. ARGUMENT .....	3
A. Summary of Argument.....	3
B. <i>Erturk</i> Fails To Teach or Suggest Performing a Finite Element Analysis on a Design of the Antenna to Determine an Estimated Output Impedance and Adjusting the Antenna if the Estimated Output Impedance does not Approximately Match the Transmitter Amplifier Output Impedance .....	4
1. Legal Standard for Establishing a Rejection Under 35 U.S.C. §102 or a Prima Facie Rejection Under 35 U.S.C. §103 .....	4
2. <i>Erturk</i> Discloses Performing Finite Element Analysis to Determine a Radiation Pattern, Not Impedance.....	4
3. <i>Erturk</i> Discloses Adjusting a Notch on a Transmission Line to Match the Impedance of the Patch Antenna .....	5
C. None of the Other Cited References Teach or Suggest Performing a Finite Element Analysis on a Design of the Antenna to Determine an Estimated Output Impedance and Adjusting the Antenna if the Estimated Output Impedance does not Approximately Match the Transmitter Amplifier Output Impedance.....	5
D. Dependent Claims .....	5
IX. CONCLUSION .....	5
APPENDIX	
A. CLAIMS ON APPEAL	
B. <i>Erturk</i> , et al., "Design/Analysis of an Active Integrated Antenna," IEEE 7/1996 pp 1322-1325 vol. 2	
C. U.S. Patent No. 5,530,919 granted to Tsuru et. al	
D. U.S. Patent No. 5,542,106 granted to Krenz et. al	
E. U.S. Patent 5,400,040 granted to Lane et. al	
F. U.S. Patent No. 6,134,420 granted to Flowerdew et. al	
G. U.S. Patent No. 4,849,767 granted to Naitou	

2 of 3

**CERTIFICATE OF MAILING 37 C.F.R. 1.8(a)**

I hereby certify that this correspondence is being deposited with the United States Postal Service with sufficient postage as first class mail in an envelope addressed to the Assistant Commissioner for Patents, Washington, D.C. 20231 on the date indicated below.

Name of Person Signing Certificate: Kelly Breeze

Date \_\_\_\_\_ Signature \_\_\_\_\_



**IN THE UNITED STATES PATENT AND TRADEMARK OFFICE**

**BEFORE THE BOARD OF PATENT APPEALS AND INTERFERENCES**

In re Appellant:	§	Confirmation No.:	3874
	§		
PAUL A. UNDERBRINK	§		
RICKE W. CLARK	§		
CHRISTIAN LEVESQUE	§		
GUANGMING YIN	§		
PATRICK D. RYAN	§		
	§		
Filed: September 13, 1999	§	Art Unit:	2685
	§		
Serial No.: 09/394,189	§	Examiner:	Charles Craver
	§		
For: DIRECTIONAL ANTENNA FOR	§	Docket No.:	600456-0023 (B64418C)
HAND-HELD WIRELESS	§		
COMMUNICATIONS DEVICE	§		
	§		
	§		
	§		
	§		

**APPEAL BRIEF**

Commissioner for Patents  
Washington, D.C. 20231

Dear Commissioner:

Appellants submit in triplicate its Appeal Brief on behalf of its assignee from the Final Rejection dated November 5, 2002. The present application is assigned to Skyworks Solutions, Inc. Timely Notice of Appeal was filed with appropriate fee with this Appeal Brief on February 5, 2003. The Commissioner is hereby authorized to charge any additional fees which may be required or credit any overpayment to Deposit Account No. 16-2435.

**I. REAL PARTY IN INTEREST**

The present application is assigned of record to Skyworks Solutions, Inc., a publicly held Delaware corporation. Its stock is publicly traded on the New York Stock Exchange.

## II. RELATED APPEALS AND INTERFERENCES

There are no other appeals or interferences which will directly affect or be directly affected by this Board's decision in the present appeal.

## III. STATUS OF THE CLAIMS

Claims 1-6, 8-12, 22-28, 30, and 31, which are all pending claims of the present application, are the appealed claims. They are set forth in their present form in Appendix A to this Brief.

## IV. STATUS OF AMENDMENTS

No amendments are pending.

## V. SUMMARY OF THE INVENTION

In brief, one embodiment of the invention relates to a system for wireless communications comprising a hand-held wireless communications device. An antenna coupled to the hand-held wireless communications device is configured to radiate with greater field intensity over an area of less than 360 degrees of arc.<sup>1</sup> A transmitter amplifier coupled to the antenna has an output impedance that matches the impedance of the antenna, where the impedance of the antenna is determined by performing a finite element analysis on a design of the antenna to determine an estimated output impedance, and the antenna is adjusted if the estimated output impedance does not approximately match the transmitter amplifier output impedance.<sup>2</sup> The antenna is oriented such that the area of less than 360 degrees of arc is in the direction away from a head of a user of the hand-held wireless communications device.<sup>3</sup>

In another embodiment, a transmit antenna is coupled to the hand-held wireless communications device. A transmitter amplifier coupled to the transmit antenna has an output impedance that matches an impedance of the transmit antenna. The impedance of the transmit antenna is determined by performing a finite element analysis on a design of the transmit antenna to determine an estimated output impedance, and the area of the transmit antenna is adjusted if the estimated output impedance does not approximately match the transmitter amplifier output impedance. A receive antenna is also coupled to the wireless communications device.

In another embodiment, a method for wireless communications is provided that comprises modulating speech data onto an electromagnetic signal. The electromagnetic signal is transmitted from a handheld device having an antenna that transmits with a greater field intensity over an area of less than 360 degrees of arc in a direction away from a head of a user. The antenna has an impedance that matches an output impedance of a transmitter amplifier of the handheld device. The impedance is determined by performing a finite element analysis on a design of the antenna to determine an estimated output impedance, and

<sup>1</sup> Specification, page 7, lines 19-30.

<sup>2</sup> Specification, page 8, lines 15-17.

<sup>3</sup> Specification, page 9, lines 15-25.

the antenna is adjusted if the estimated output impedance does not approximately match the transmitter amplifier output impedance.

In another embodiment, a method for wireless communications is provided that comprises determining the output impedance of a transmitter amplifier of a wireless device. A finite element analysis is performed on a design of a patch antenna to determine an estimated output impedance. The area of the patch antenna is adjusted if the estimated output impedance does not approximately match the transmitter amplifier output impedance. The patch antenna is then provided for use with the wireless device.

## VI. ISSUES ON APPEAL

Whether claim 27 is unpatentable over Erturk, et al., "Design/Analysis of an Active Integrated Antenna," IEEE 7/1996 pp 1322-1325 vol. 2 ("*Erturk*") under 35 U.S.C. §102. Whether claims 1-4, 6, 8, 9, 11, 12, 22-26 and 31 are unpatentable under 35 U.S.C. §103(a) over U.S. Patent No. 5,530,919 granted to Tsuru et. al ("*Tsuru*") in view of U.S. Patent No. 5,542,106 granted to Krenz et. al ("*Krenz*"), U.S. Patent 5,400,040 granted to Lane et al. ("*Lane*") and *Erturk*. Whether claims 5 and 10 are unpatentable under 35 U.S.C. §103(a) over *Tsuru* in view of *Krenz*, *Lane*, and *Erturk*, and further in view of U.S. Patent No. 6,134,420 granted to Flowerdew et al. ("*Flowerdew*"). Whether claim 28 is unpatentable under 35 U.S.C. §103(a) over *Erturk*. Whether claim 30 is unpatentable under 35 U.S.C. §103(a) over *Erturk* and further in view of U.S. Patent No. 4,849,767 granted to Naitou ("*Naitou*").

## VII. GROUPING OF THE CLAIMS

The claims on appeal stand or fall together:

Claim 1 will be discussed below as illustrative of the scope of the claims.

## VIII. ARGUMENT

### A. Summary of Argument

Appellants respectfully submit that in rejecting claim 27 over *Erturk*, claims 1-4, 6, 8, 9, 11, 12, 22-26 and 31 over *Tsuru* in view of *Krenz*, *Lane*, and *Erturk*, claims 5 and 10 over *Tsuru* in view of *Krenz*, *Lane*, and *Erturk*, and further in view of *Flowerdew*, claim 28 over *Erturk*, and claim 30 over *Erturk* and further in view of *Naitou*, the Examiner has failed to establish a prima facie basis for the rejection of these claims, as the cited prior fails to disclose or suggest each element of the claimed invention.

Neither *Tsuru*, *Krenz*, *Lane*, *Erturk*, *Flowerdew*, or *Naitou* teach or suggest determining the impedance of an antenna by performing a finite element analysis on a design of the antenna to determine an estimated output impedance, and adjusting the antenna if the estimated output impedance does not approximately match the transmitter amplifier output impedance.

B. *Erturk* Fails To Teach or Suggest Performing a Finite Element Analysis on a Design of the Antenna to Determine an Estimated Output Impedance and Adjusting the Antenna if the Estimated Output Impedance does not Approximately Match the Transmitter Amplifier Output Impedance

1. Legal Standard for Establishing a Rejection Under 35 U.S.C. §102 or a Prima Facie Rejection Under 35 U.S.C. §103

In order to establish a rejection under 35 U.S.C. §102, the reference must teach every aspect of the claimed invention either explicitly or impliedly.<sup>4</sup> In order to establish a prima facie case for rejection under 35 U.S.C. §103, all of the claim limitations must be taught or suggested by the prior art.<sup>5</sup> In either case, the burden is on the Examiner to show that each claim limitation is taught or suggested by the prior art.

2. *Erturk* Discloses Performing Finite Element Analysis to Determine a Radiation Pattern, Not Impedance

The Examiner asserts that *Erturk* discloses “performing a finite-element analysis on the design of the antenna so as to *optimize the impedance* of the antenna (page 1 line 29-page 2 line 19) . . . *inherently comprising steps of determining the transmitter impedance* as well as the estimated impedance of the antenna.”<sup>6</sup> (*Emphasis added*). However, a review of the cited sections reveals that *Erturk* does not disclose what it is alleged to:

The output port of the active device is directly connected to a microstrip patch antenna via a microstrip line. By introducing a notch, whose width is optimized with a modified transmission line model, the input impedance of the antenna at resonance is matched to the characteristic impedance of the microstrip line. . . . We are using two different FDTD models for the radiation pattern calculation.

It is further noted in the Introduction section of *Erturk* that “[r]adiation patterns are calculated using two different FDTD models of the antenna and compared with measurements.” Thus, it is apparent that the purpose of performing the finite difference time domain (FDTD) analysis is for determining the radiation pattern, and not for determining the impedance of an antenna to determine an estimated output impedance, and adjusting the antenna if the estimated output impedance does not approximately match the transmitter amplifier output impedance. All impedance adjustment occurs at the microstrip line by introducing a notch whose width is optimized using a modified transmission line model. Therefore, *Erturk* fails to disclose performing a finite element analysis to determine impedance, and instead only discloses performing an FDTD analysis to determine the radiation pattern.

<sup>4</sup> MPEP § 706.02

<sup>5</sup> MPEP § 706.02(j).

<sup>6</sup> Paragraph 2, page 2, Paper no. 15, mailed November 5, 2002.



3. *Erturk* Discloses Adjusting a Notch on a Transmission Line to Match the Impedance of the Patch Antenna, and Does Not Disclose Adjusting the Impedance of the Patch Antenna

In addition, *Erturk* does not inherently comprise steps of determining the transmitter impedance as well as the estimated impedance of the antenna. Instead, the impedance of the microstrip line is adjusted to match the impedance of the antenna at resonance by introducing a notch in the microstrip transmission line whose width is optimized using a modified transmission line model. It is clear that impedance matching between the antenna and the transmission line is being performed for the usual reasons associated with impedance matching between a transmission line and a load, such as to improve the transmission efficiency and stability of the transmission line. Therefore, *Erturk* fails to disclose adjusting the impedance of the antenna to match the transmitter, and instead discloses adjusting the impedance of the transmission line to match the resonance impedance of the antenna. In *Erturk*, it is the radiation pattern of the antenna that is of primary concern, not the impedance.

C. None of the Other Cited References Teach or Suggest Performing a Finite Element Analysis on a Design of the Antenna to Determine an Estimated Output Impedance and Adjusting the Antenna if the Estimated Output Impedance does not Approximately Match the Transmitter Amplifier Output Impedance

The Examiner admits that *Tsuru* does not disclose finite element analysis of the antenna and adjustment of the antenna impedance to match the transmitter impedance.<sup>7</sup> Likewise, neither *Krenz*, *Lane*, *Erturk*, *Flowerdew*, nor *Naitou* disclose performing a finite element analysis on a design of an antenna to determine an estimated output impedance, and adjusting the antenna if the estimated output impedance does not approximately match the transmitter amplifier output impedance. Thus, none of these other references provide the missing aspect or limitations that *Erturk* fails to provide.

D. Dependent Claims

With respect to claims 2-6, 9-12, 23-36, 28, 30 and 31, these claims depend on allowable claims 1, 8, 22, and 27. Rejection of dependent claims of allowable claims is erroneous.

IX. CONCLUSION

For reasons set forth in detail above, it is respectfully submitted that the rejection of claim 27 under 35 U.S.C. § 102(b) and of claims 1-6, 8-12, 22-26, 28, 30 and 31 under 35 U.S.C. § 103(a) are erroneous. As shown above, *Erturk* fails to teach or suggest determining the impedance of an antenna by performing a finite element analysis on a design of the antenna to determine an estimated output impedance, and adjusting the antenna if the estimated output impedance does not approximately match the transmitter amplifier output impedance. Therefore, Appellants' claimed subject matter is not anticipated and cannot be rendered obvious by the cited references.

<sup>7</sup> Paragraph 4, page 3, Paper no. 12, mailed May 12, 2002.

Reversal of the final rejection of the claims is the appropriate action for this board. Such action is respectfully requested.

Respectfully submitted,

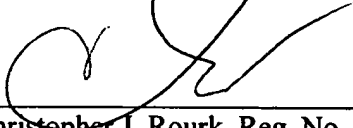

Christopher J. Rourk, Reg. No. 39,348

Date: 2/5/03

AKIN GUMP STRAUSS HAUER & FELD LLP  
1700 Pacific Avenue, Suite 4100  
Dallas, Texas 75201  
(214) 969-4669  
(214) 969-4343 Fax

# Appendix A

# APPENDIX A

## CLAIMS ON APPEAL (AS AMENDED 3/29/2001)

1. A system for wireless communications comprising:
  - a hand-held wireless communications device;
  - an antenna coupled to the hand-held wireless communications device, the antenna configured to radiate with greater field intensity over an area of less than 360 degrees of arc;
  - a transmitter amplifier coupled to the antenna, the transmitter amplifier having an output impedance that matches the impedance of the antenna, the impedance of the antenna determined by performing a finite element analysis on a design of the antenna to determine an estimated output impedance, and adjusting the antenna if the estimated output impedance does not approximately match the transmitter amplifier output impedance; and
  - wherein the antenna is oriented such that the area of less than 360 degrees of arc is in the direction away from a head of a user of the hand-held wireless communications device.
  
2. The system of claim 1 wherein the antenna is a patch antenna that is provided so as to filter the radiated signal by radiating the radiated signal within a narrow, predetermined band.
  
3. The system of claim 1 wherein the antenna is a patch antenna that is configured to radiate with greater field intensity over an area of less than 360 degrees of arc.
  
4. The system of claim 1 wherein the antenna is a loop antenna that is configured to radiate with greater field intensity over an area of 180 degrees of arc.
  
5. The system of claim 1 further comprising a receive antenna coupled to the hand-held wireless communications device, wherein the receive antenna has an orthogonal field of reception relative to the antenna.

6. The system of claim 1 further comprising a receive antenna coupled to the hand-held wireless communications device, wherein the receive antenna is a patch antenna.

8. A system for wireless communications comprising:  
a hand-held wireless communications device;  
a transmit antenna coupled to the hand-held wireless communications device;  
a transmitter amplifier coupled to the transmit antenna, the transmitter amplifier having an output impedance that matches an impedance of the transmit antenna, the impedance of the transmit antenna determined by performing a finite element analysis on a design of the transmit antenna to determine an estimated output impedance, and adjusting the area of the transmit antenna if the estimated output impedance does not approximately match the transmitter amplifier output impedance; and  
a receive antenna coupled to the wireless communications device.

9. The system of claim 8 wherein the hand-held wireless communications device is a cellular telephone.

10. The system of claim 8 wherein the transmit antenna has a transmit field that is orthogonal to the reception field of the receive antenna.

11. The system of claim 8 wherein the transmit antenna and the receive antenna are each patch antennas, and are each contained within a housing of the hand-held wireless communications device.

12. The system of claim 8 wherein the transmit antenna and the receive antenna are each patch antennas, and are each contained within an integrated circuit package.

22. A method for wireless communications comprising:  
modulating speech data onto an electromagnetic signal;

transmitting the electromagnetic signal from a handheld device having an antenna that transmits with a greater field intensity over an area of less than 360 degrees of arc in a direction away from a head of a user; and

wherein the antenna has an impedance that matches an output impedance of a transmitter amplifier of the handheld device, the impedance determined by performing a finite element analysis on a design of the antenna to determine an estimated output impedance, and adjusting the antenna if the estimated output impedance does not approximately match the transmitter amplifier output impedance.

23. The method of claim 22 further comprising receiving an incoming electromagnetic signal at a second antenna.

24. The method of claim 22 wherein transmitting the electromagnetic signal from the handheld device having the antenna that transmits in the direction away from the head of the user further comprises transmitting the electromagnetic signal from a patch antenna.

25. The method of claim 22 further comprising receiving an incoming electromagnetic signal at a patch antenna.

26. The method of claim 22 further comprising receiving an incoming electromagnetic signal at a monopole antenna.

27. A method for wireless communications comprising:  
determining the output impedance of a transmitter amplifier of a wireless device;  
performing a finite element analysis on a design of a patch antenna to determine an estimated output impedance;  
adjusting the area of the patch antenna if the estimated output impedance does not approximately match the transmitter amplifier output impedance; and  
providing the patch antenna for use with the wireless device.

28. The method of claim 27 wherein the output impedance of the transmitter amplifier is approximately 10 ohms.

30. The method of claim 27 further comprising adjusting the pass band characteristic of the patch antenna to reduce the need for filtering of a received signal having predetermined frequency characteristics.

31. The system of claim 1 further comprising at least two base stations, wherein the hand-held wireless communications device communicates with one of the base stations when it is oriented in a first direction and with the other of the base stations when it is oriented in a second direction.

# Appendix B



## Design/Analysis of an Active Integrated Antenna <sup>†</sup>

V.B. Erturk\*, R.G.Rojas and P. Roblin  
The Ohio State University ElectroScience Laboratory.  
Columbus, Ohio 43212-1191

**Introduction:** Active integrated antennas are becoming the essential components in the field of wireless communications due to their low cost, simplicity of design and small size [1]. Therefore, it is important to have analysis and design methods which are accurate and efficient as well as designs of active integrated antennas that satisfy the most important specifications in the area of wireless communications. In this paper, we introduce an active integrated antenna design and analysis approach based on a hybrid combination of full wave/nonlinear circuit solvers. A prototype antenna working at 2.01 GHz is designed and fabricated using a low cost medium power Silicon Bipolar Transistor. Radiation patterns are calculated with two different FDTD models of the antenna and compared with measurements. Numerical and experimental results for the radiation patterns are found to be in good agreement and the cross-polarizations in the main beam region are 30dB and 25dB down in the H- and E-planes, respectively .

**Design and Analysis:** The active integrated antenna consists of a microstrip patch antenna, a Silicon Bipolar Transistor, termination, feedback and bias circuitry, as seen in Figure 1.

Following the negative resistance technique [2]: i) An NPN-active biasing circuit is modeled in Libra [3] and a non-linear model of the transistor is biased to make it work in the active region. ii) The transistor is forced to become potentially unstable and a negative impedance at the frequency of oscillation is obtained by using open circuit stubs as termination and feedback. A low frequency resistive negative feedback is also added to prevent low-frequency oscillations.

The output port of the active device is directly connected to a microstrip patch antenna via a microstrip line. By introducing a notch, whose width is optimized with a modified transmission line model, the input impedance of the antenna at resonance is matched to the characteristic impedance of the microstrip line. The passive components, whose time and frequency domain characteristics including mutual coupling are obtained with a FDTD algorithm, are modeled as a 4-port network and represented by the corresponding scattering matrix. The non-diagonal elements of the S-matrix which correspond to the values of mutual coupling can be neglected, since they were found to be small.

---

<sup>†</sup>This work is supported in part by Trimble Navigation, the Joint Services Electronics Program (Contract N00014-89-J-1007) and by The Ohio State University Research Foundation.

The design is finally verified by using an improved Kurokawa scheme which combines the 4-port S-matrix with the nonlinear model of the transistor.

We are using two different FDTD models for the radiation pattern calculations. The first model assumes an infinite ground plane and is based on the reciprocity theorem; namely the radiation pattern of the antenna is obtained by calculating the equivalent phasor electric currents on the patch and microstrip line. This model is useful because it allows us to predict the performance of the antenna itself since the diffraction from the edges of the ground plane is neglected. The second model assumes a finite ground plane and is based on the surface equivalence theorem; namely a virtual surface enclosing the antenna is chosen, the equivalent phasor electric and magnetic currents on this surface are calculated and integrated with the free-space Green's function weighting to obtain far-field pattern [4]. In this method, the distortion in the patterns due to the edge diffracted fields should be visible since the effect of ground plane is taken into consideration. In both approaches a DFT algorithm is used inside the FDTD code for the calculation of equivalent currents. Note that by subtracting the radiation pattern results of the first model from the result of the second model, the contribution from the edges of the ground plane can be obtained. In other words, the edge diffracted fields are obtained numerically.

**Results and Conclusion:** Figure 2 shows the measured frequency spectrum at 2.01 GHz of the active antenna. Figure 3 and Figure 4 show both the measured and calculated E- and H-plane radiation patterns, respectively. The calculated results are for the case where the substrate is assumed to be infinite in size. Therefore, these results do not include the effect of the edges. Additional computed results will be presented where the effect of the edges of the ground plane are taken into account and compared with the measured data.

In conclusion, a prototype working at 2.01 GHz active integrated antenna is designed and analyzed with a combination of full wave/nonlinear circuit solvers. The design shows good oscillator characteristics and good agreement between the numerical and experimental results.

#### References:

- [1] J.Lin and T. Itoh, "Active Integrated Antennas", *IEEE Trans. Microwave Theory Tech.*, vol.42, pp.2186-2194, Dec.94
- [2] G.D.Vendelin, A.M.Rohde, and U.L.Rohde, "Microwave Circuit Design Using Linear and Nonlinear Techniques" John Wiley & Sons, New York, 1990.
- [3] "Libra User's Guide" EEsof Inc., 1993.
- [4] A. Taflov, "Computational Electrodynamics The Finite-Difference Time-Domain Method." Artech House, Boston, Massachusetts, 1995.

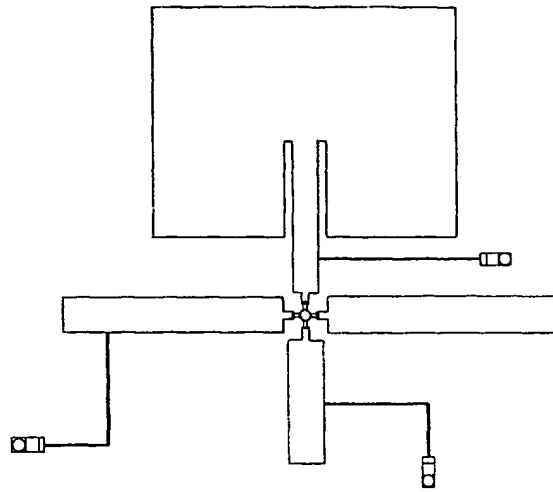

Figure 1: Configuration of active integrated microstrip antenna.

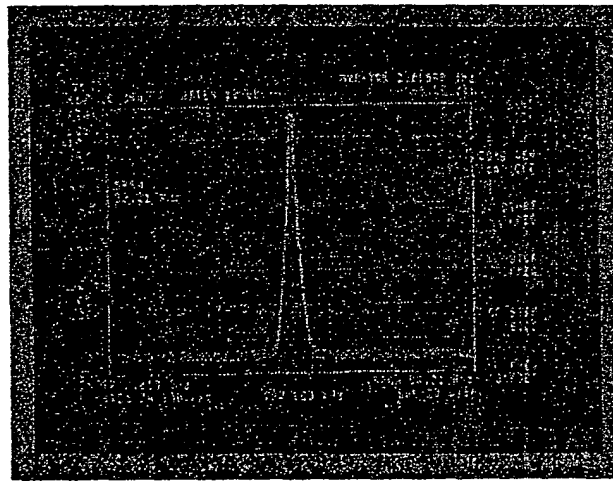

Figure 2: Measured frequency spectrum of the oscillator. Center frequency is 2.019 GHz, Res.BW=300 kHz, Hor.div=5.021 MHz , Ver.div=10dB.

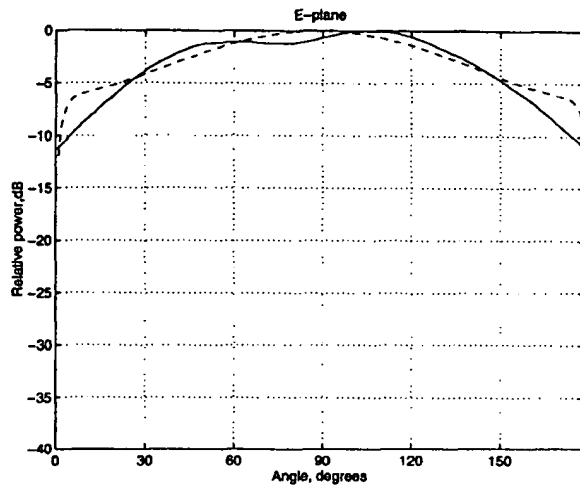

Figure 3: Experimental and numerical results for the E-plane radiation pattern of the active integrated antenna. solid line: experimental result, dashed line: numerical result for antenna with infinite ground plane.

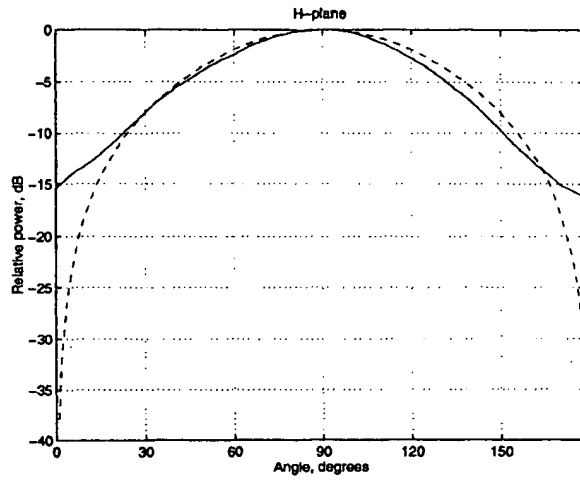

Figure 4: Experimental and numerical results for the H-plane radiation pattern of the active integrated antenna. solid line: experimental result, dashed line: numerical result for antenna with infinite ground plane.

Appendix c



US005530919A

# United States Patent [19]

[11] Patent Number: 5,530,919

Tsuru et al.

[45] Date of Patent: Jun. 25, 1996

[54] MOBILE COMMUNICATOR WITH MEANS FOR ATTENUATING TRANSMITTED OUTPUT TOWARD THE USER

5,392,461 2/1995 Yokoyama ..... 455/90

[75] Inventors: Teruhisa Tsuru; Harufumi Mandai, both of Nagaokakyo, Japan

### FOREIGN PATENT DOCUMENTS

0214806 3/1987 European Pat. Off. .

[73] Assignee: Murata Manufacturing Co., Ltd., Japan

### OTHER PUBLICATIONS

Patent Abstracts Of Japan, vol. 16, No. 570 (E-1297) 10 Dec. 1992 & Jp-A-04 220 851 (Mitsubishi) 11 Aug. 1992, (Abstract).

European Search Report dated Jan. 24, 1995.

The Sharper Image Catalog, Jun. 1994, pp. 22.

Microstrip Antennas, I. J. Bahl and P. Bhartia, 1980, pp. 26-29.

Small Antennas, K. Fujimoto et al., 1987, pp. 116-119, 147, 197-199.

[21] Appl. No.: 239,022

[22] Filed: May 6, 1994

[30] Foreign Application Priority Data

Oct. 12, 1993 [JP] Japan ..... 5-254298

Mar. 1, 1994 [JP] Japan ..... 6-031523

[51] Int. Cl.<sup>6</sup> ..... H04B 1/38

[52] U.S. Cl. .... 455/90; 455/89; 455/128; 455/129

[58] Field of Search ..... 455/89, 90, 128, 455/129, 300, 301; 361/800, 816, 818; 343/700 MS, 702, 841, 899

Primary Examiner—Reinhard J. Eisenzopf

Assistant Examiner—Marsha D. Banks-Harold

Attorney, Agent, or Firm—Ostrolenk, Faber, Gerb & Soffen

### [57] ABSTRACT

Disclosed herein is a mobile communicator comprising an antenna (3) built in a portable telephone body (1), and a circuit board (2) built in the communicator body (1) and provided with a ground electrode pattern (2a) arranged between an outer surface part (1a), which is brought into contact with or near a portion of a human head, and the antenna (3). A transmission output of the antenna (3) toward the human head is attenuated by the ground electrode pattern (2a) of the circuit board (2).

### [56] References Cited

#### U.S. PATENT DOCUMENTS

4,899,164	2/1990	McGrath	343/700
5,150,282	9/1992	Tomura et al.	455/300
5,153,600	10/1992	Metzler et al.	343/700
5,170,173	12/1992	Krenz et al.	343/702
5,335,366	8/1994	Daniels	379/59

18 Claims, 8 Drawing Sheets

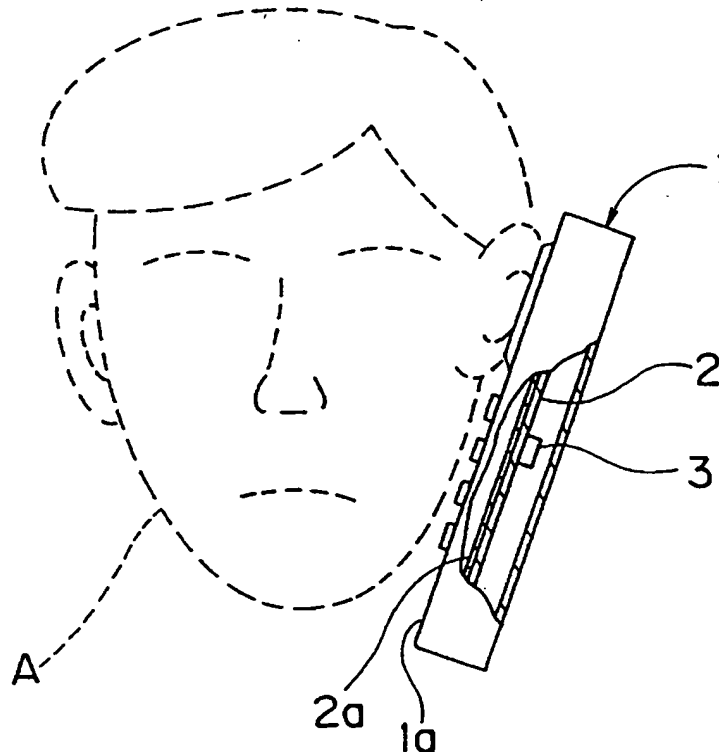

FIG. 1

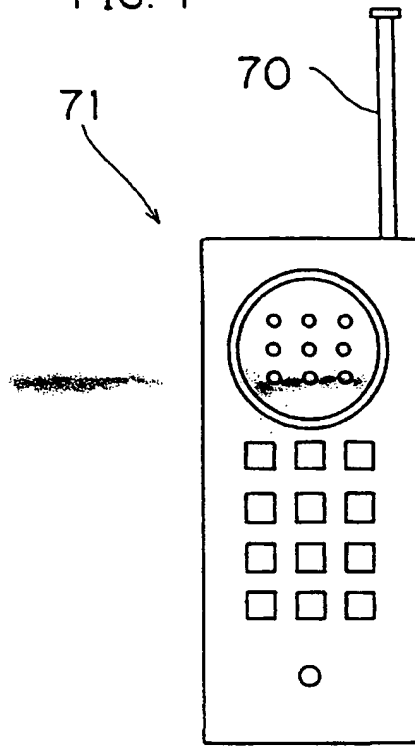

FIG. 2

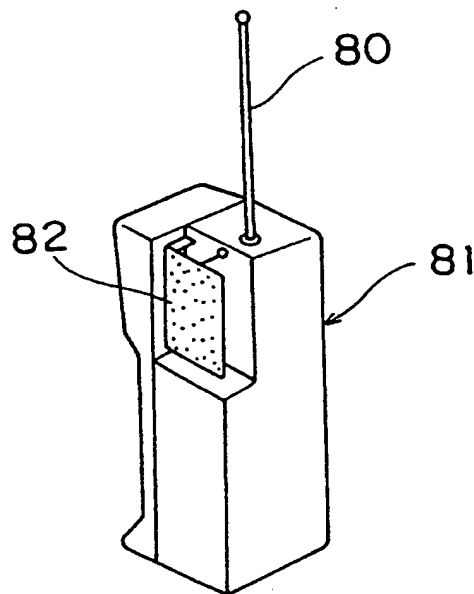

FIG. 3

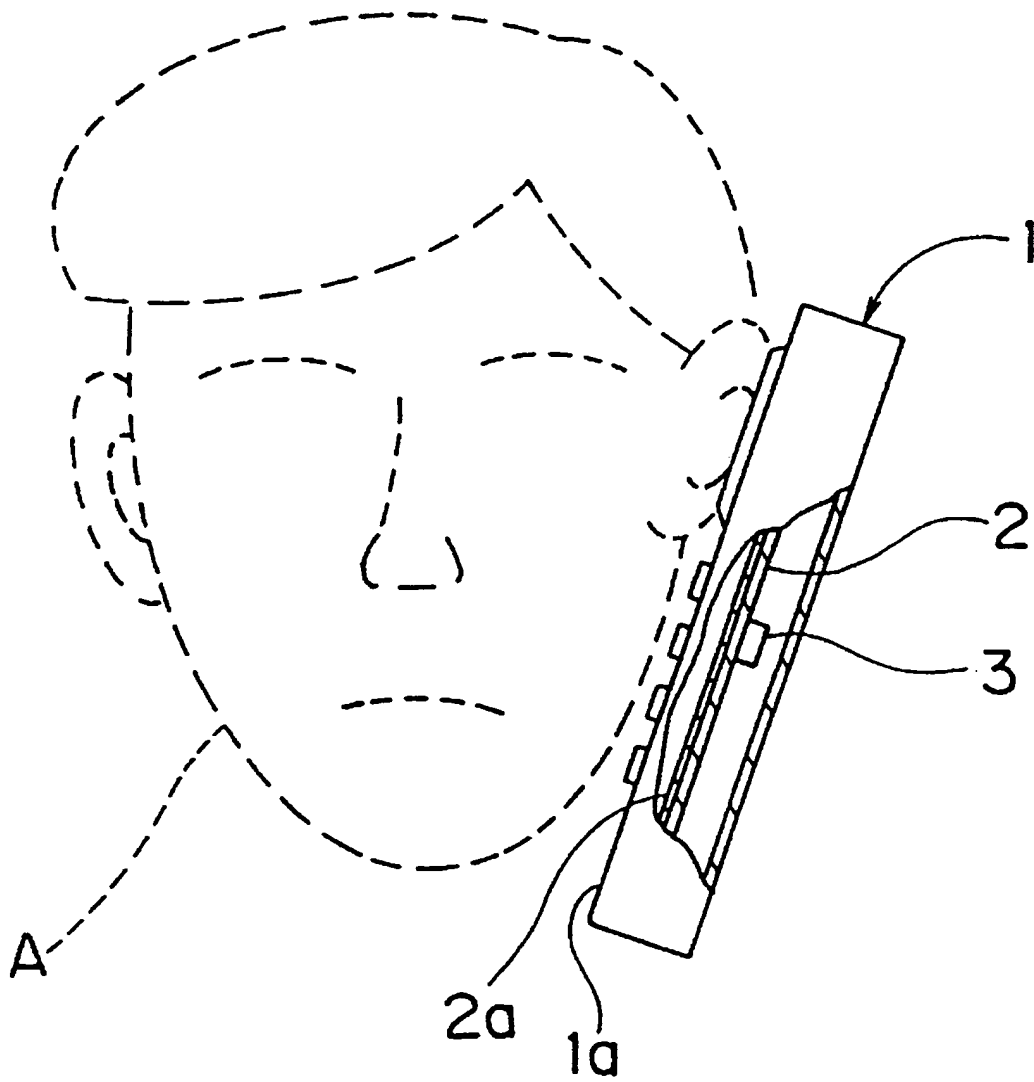



FIG. 4 A

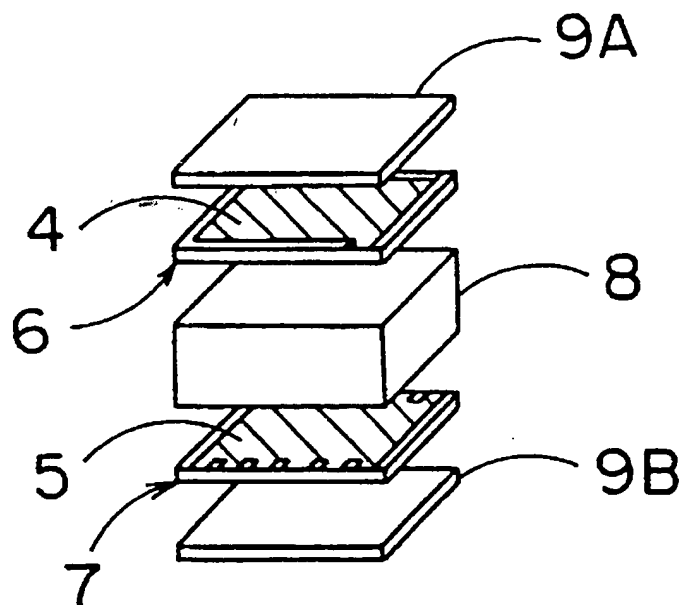

FIG. 4 B

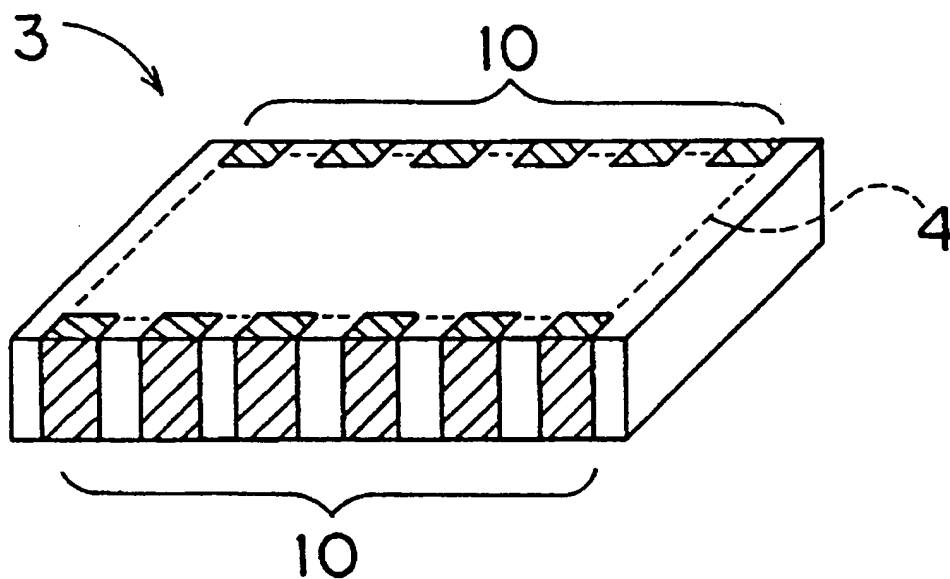

FIG. 5

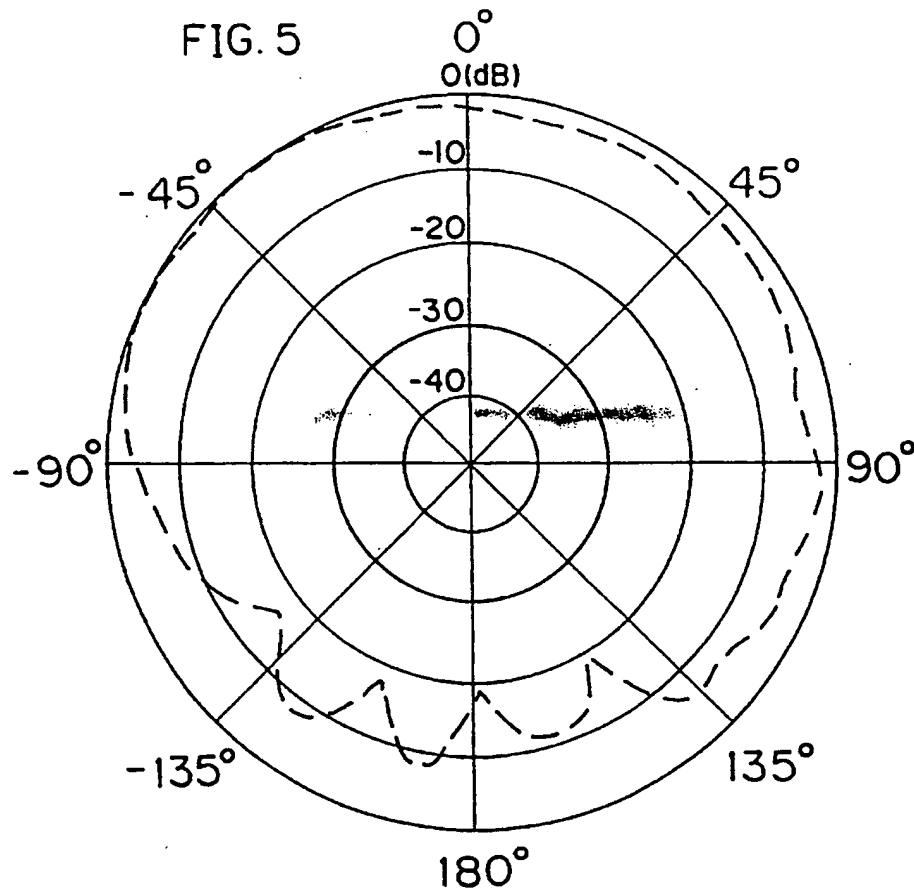

FIG. 6

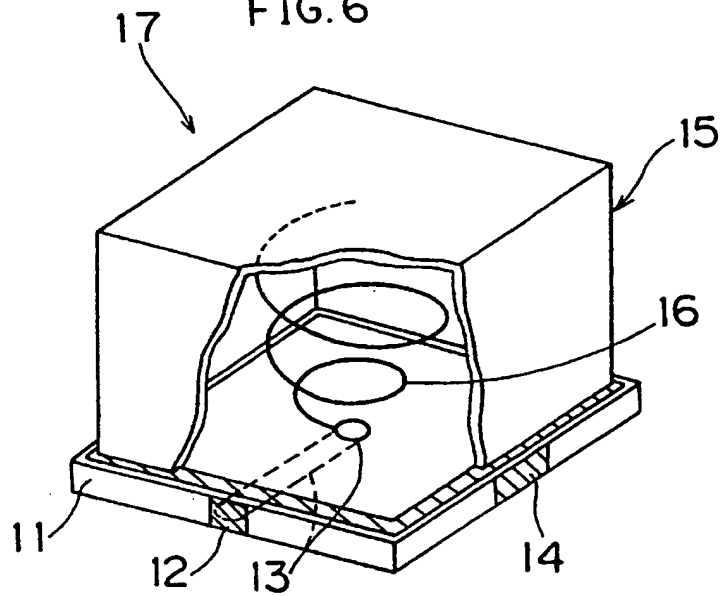

FIG. 7

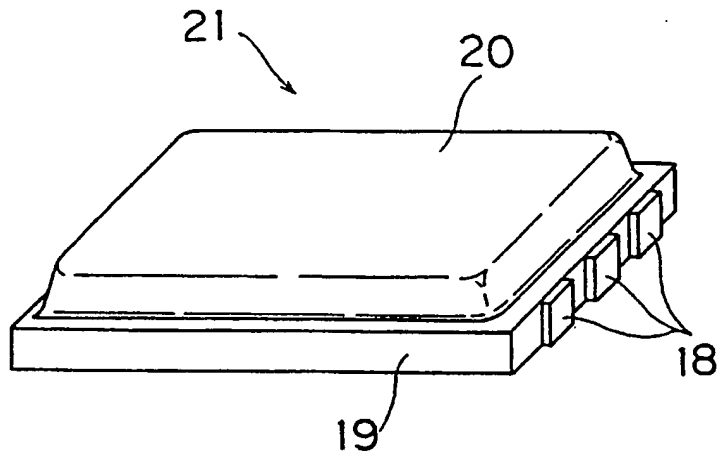

FIG. 8

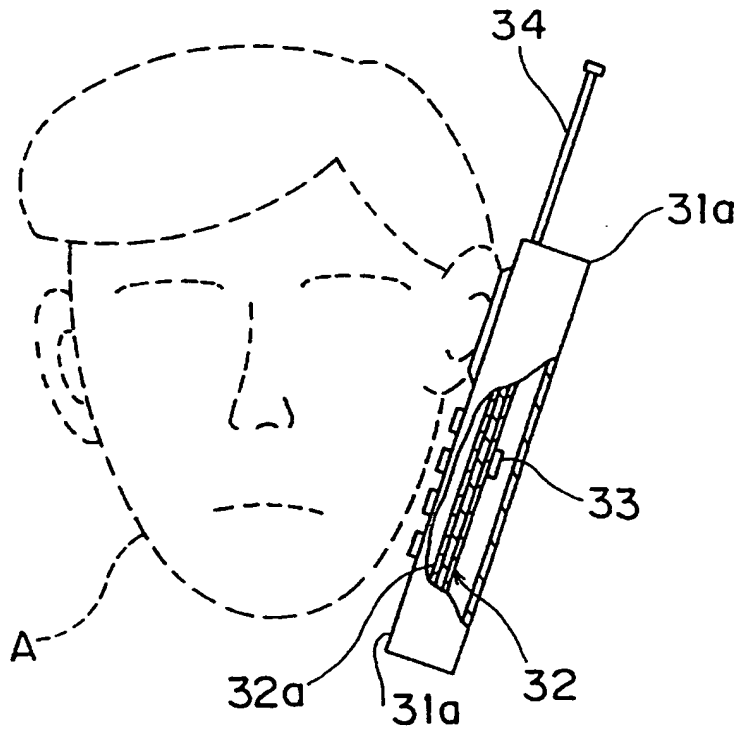

FIG. 9

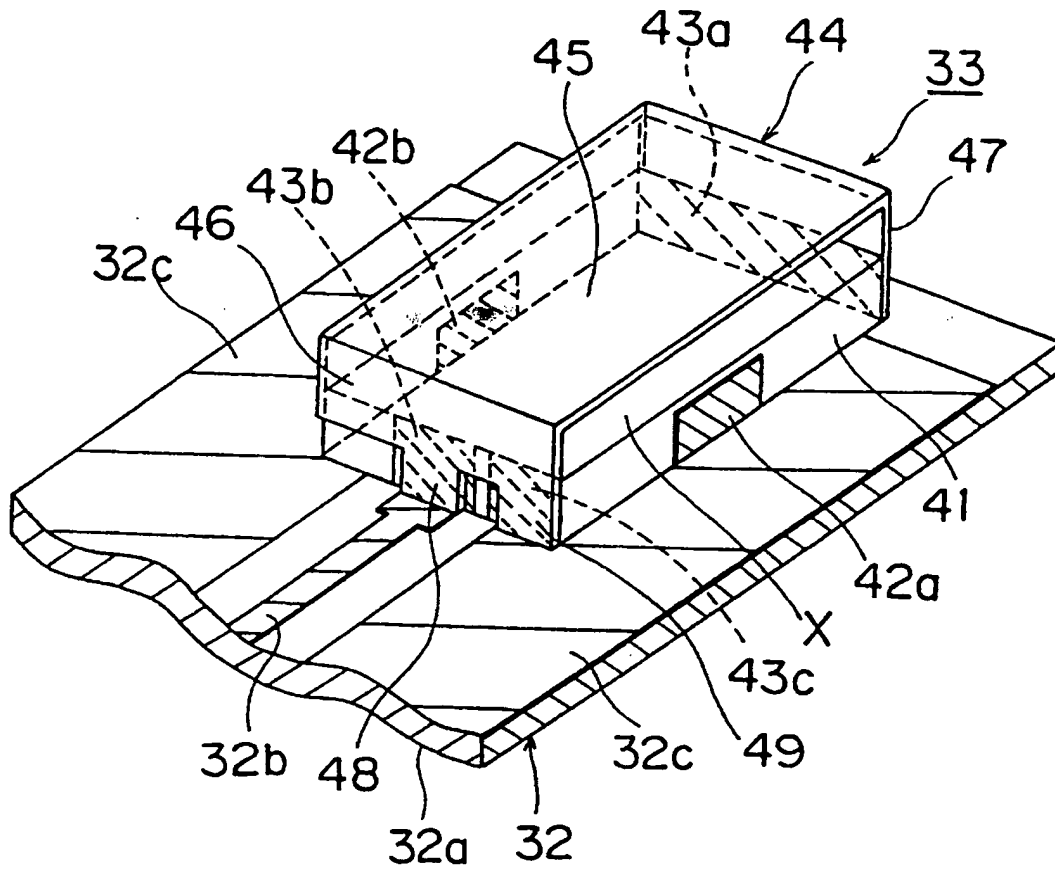

FIG. 10

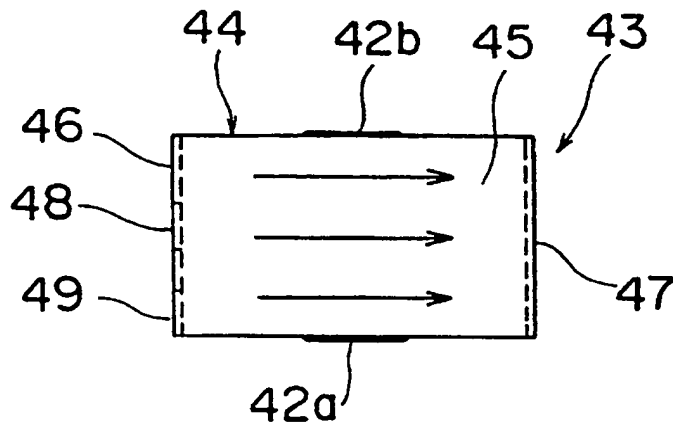

FIG. 11

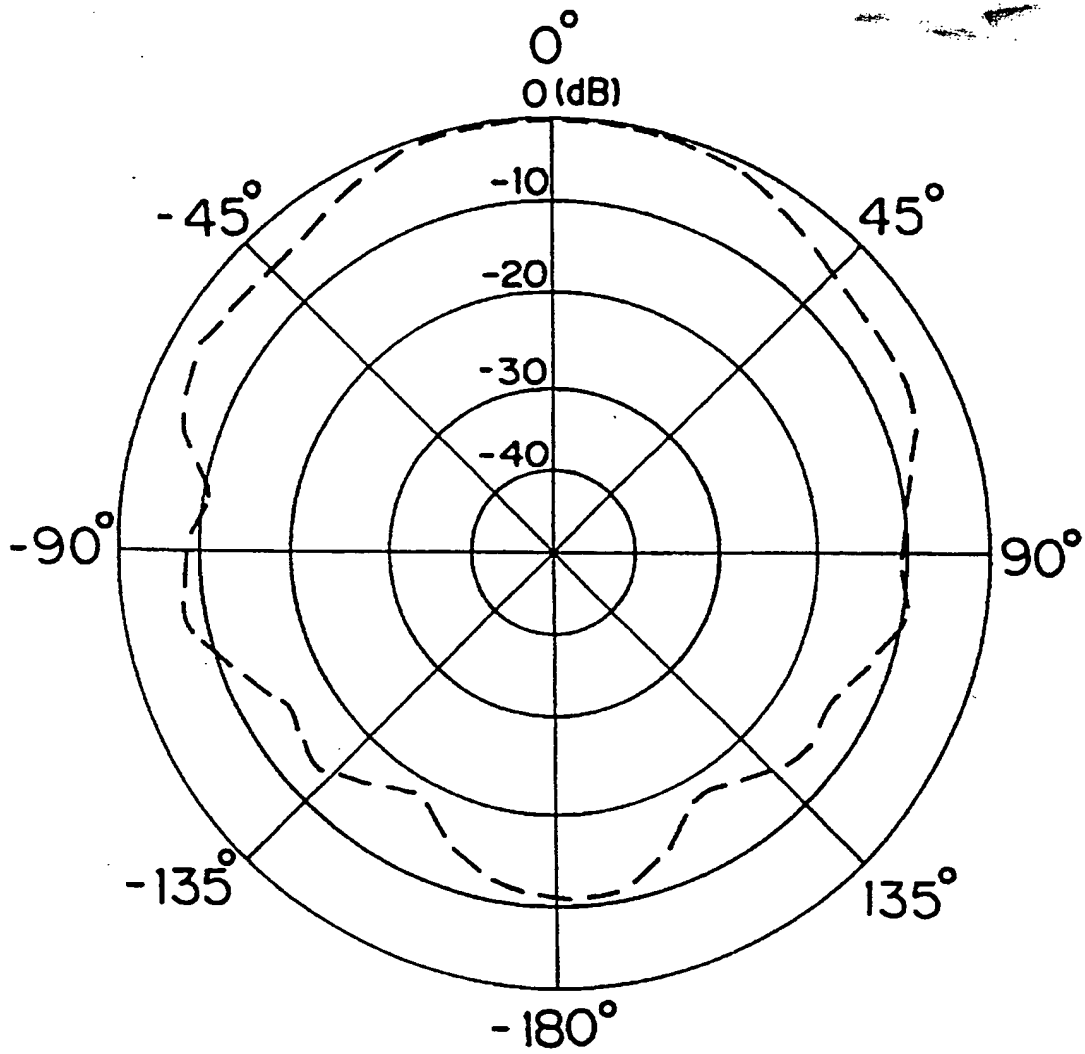
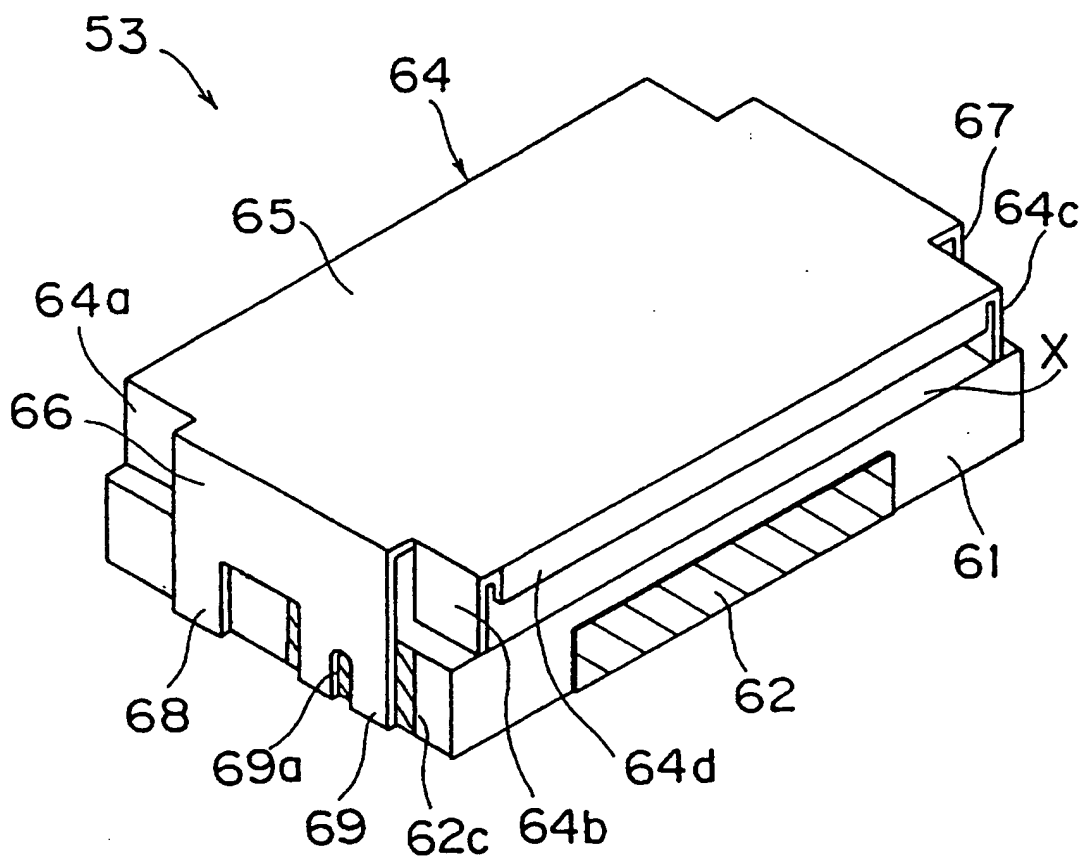

FIG. 12



1

# MOBILE COMMUNICATOR WITH MEANS FOR ATTENUATING TRANSMITTED OUTPUT TOWARD THE USER

## BACKGROUND OF THE INVENTION

### 1. Field of the Invention

The present invention relates to a mobile communicator, and more particularly, it relates to an improvement in a mobile communicator having a built-in antenna.

### 2. Description of the Background Art

FIG. 1 shows a portable telephone 71 which is an example of a conventional mobile communicator. An omnidirectional whip antenna 70 is mounted to project from an upper portion of the portable telephone 71, for transmitting electric waves.

FIG. 2 shows another exemplary conventional portable telephone 81 which is known in the art. An omnidirectional whip antenna 80 is mounted on an upper portion of this portable telephone 81, while a plate-type inverted-F antenna 82 is mounted in the interior of the portable telephone 81. The whip antenna 80 is adapted to transmit electric waves while the inverted-F antenna 82 is adapted to receive electric waves, so that a diversity unit is formed by the whip antenna 80 and the inverted-F antenna 82.

In relation to the aforementioned conventional mobile communicators, however, it has recently been pointed out that the electric waves transmitted by the omnidirectional whip antennas 70 and 80 are also radiated toward a portion of the human head, which is believed by some to exert an undesirable influence on the human body.

## SUMMARY OF THE INVENTION

The present invention has been proposed in order to solve such a problem of the prior art, and an object thereof is to provide a mobile communicator which can reduce any influence exerted on a human body by transmitted electric waves.

According to a broad aspect of the present invention, provided is a mobile communicator comprising a communicator body having an outer surface part which is brought into contact with or close to a human head portion, an antenna which is built into the communicator body, and an attenuating means which is arranged between the outer surface part of the communicator body brought into contact with or close to the human head portion and the antenna for attenuating a transmission output from the antenna toward the human head portion.

The expression "between the outer surface part and the antenna" also includes the outer surface part itself.

According to the present invention, it is possible to reduce the strength of electromagnetic waves which are radiated toward the human body in transmission, due to the means provided between the outer surface part being brought into contact with or near the human head portion and the antenna built into the communicator. Thus, it is possible to reduce any influence which may be exerted on the human body by the electromagnetic waves radiated from the antenna.

The means for attenuating the transmission output from the antenna toward the human head portion can be formed by a circuit board which is arranged between the antenna and the outer surface part of the communicator body brought into contact with or near the human head portion and provided with a ground electrode pattern. Namely, it is possible to effectively suppress propagation of the electromagnetic waves radiated from the antenna toward the human

2

head portion by connecting the ground electrode pattern to a reference potential such as a ground potential, for example.

Preferably, the antenna is surface-mounted on a surface of the circuit board which is opposite to that close to the human head portion, thereby miniaturizing the mobile communicator.

According to a specific aspect of the present invention, the mobile communicator comprises a second antenna for receiving, which is mounted on the communicator body to outwardly project from the communicator body, in addition to the built-in antenna, and the built-in antenna is utilized as a transmission antenna, thereby forming a diversity unit. According to this structure, the means for attenuating the transmission output toward the human head portion is arranged between the antenna and the human body in a radiation path of the electric waves transmitted from the built-in antenna, whereby it is possible to attenuate the transmission output toward the human head portion, i.e., to attenuate electromagnetic waves which are transmitted toward the human head portion. In receiving, on the other hand, electromagnetic waves are received by the second antenna, and hence receiving sensitivity can be easily improved by devising the second antenna appropriately.

According to another specific aspect of the present invention, the built-in antenna comprises a dielectric substrate, a ground electrode which is formed on at least one of a side surface and a bottom surface of the dielectric substrate, a radiator of a material having low conductor loss which is fixed to the dielectric substrate so that its first major surface is opposed to that of the dielectric substrate, and a feed part which is provided on at least one of a side surface and a bottom surface of a laminate formed by the dielectric substrate and the radiator. Since the ground electrode is arranged on the side or bottom surface of the dielectric substrate and the feed part is arranged on the side or bottom surface of the laminate, the antenna can be easily surface-mounted on a printed circuit board or the like, with a major surface of the dielectric substrate, which is opposite to that provided with the radiator, serving as a mounting surface. Further, the radiator is made of a material having low conductor loss such as a metal plate, for example, whereby an electrical resistance component of the antenna is reduced and its heat capacity is increased. Thus, Joule loss is reduced and hence it is possible to improve the gain of the built-in antenna, thereby facilitating miniaturization of the communicator body.

In particular, a space of a prescribed thickness is more preferably provided between the dielectric substrate and the radiator, thereby effectively suppressing loss of radiated electric waves. Thus, it is possible to further effectively improve the gain of the antenna.

The foregoing and other objects, features, aspects and advantages of the present invention will become more apparent from the following detailed description of the present invention when taken in conjunction with the accompanying drawings.

## BRIEF DESCRIPTION OF THE DRAWINGS

FIG. 1 is a front elevational view showing an exemplary conventional portable telephone;

FIG. 2 is a partially broken away perspective view showing another exemplary conventional portable telephone;

FIG. 3 is a partially fragmented front sectional view for illustrating a portable telephone according to a first embodiment of the present invention;

3

FIG. 4A is an exploded perspective view for illustrating an exemplary antenna which is employed for the first embodiment of the present invention, and FIG. 4B is a perspective view of the antenna;

FIG. 5 illustrates a directional pattern of the antenna shown in FIG. 4B;

FIG. 6 is a partially fragmented perspective view for illustrating another exemplary antenna which is employed for the first embodiment of the present invention;

FIG. 7 is a perspective view showing still another exemplary antenna which is employed for the first embodiment of the present invention;

FIG. 8 is a partially fragmented front sectional view for illustrating a state of employment of a portable telephone according to a second embodiment of the present invention;

FIG. 9 is a partially fragmented perspective view for illustrating an exemplary built-in antenna which is employed for the second embodiment of the present invention;

FIG. 10 is a plan view for illustrating the direction of a high-frequency current flowing in a metal chassis in the antenna shown in FIG. 9;

FIG. 11 illustrates a directional pattern of the antenna shown in FIG. 9; and

FIG. 12 is a perspective view for illustrating another exemplary antenna which is employed for the second embodiment of the present invention.

#### DESCRIPTION OF PREFERRED EMBODIMENTS

FIG. 3 is a partially fragmented front sectional view showing a state of employment of a mobile communicator according to a first embodiment of the present invention. The mobile communicator according to this embodiment is employed as a portable telephone.

Referring to FIG. 3, a portable telephone body 1 is formed by a case which is substantially in the form of a rectangular parallelepiped. One major surface of this portable telephone body 1 forms an outer surface part 1a which is brought close to a human head portion A schematically shown by broken lines.

A circuit board 2 is built in the portable telephone body 1. This circuit board 2 has a ground electrode pattern 2a. The ground electrode pattern 2a is formed on a major surface of the circuit board 2 which is closer to the human head portion A, to have a certain degree of area. The circuit board 2 is mounted in parallel with the outer surface part 1a, while an antenna 3 is mounted on another major surface of the circuit board 2 which is opposite to that close to the human head portion A.

In the portable telephone according to this embodiment, the ground electrode pattern 2a, which is connected to an earth potential, forms means for attenuating a transmission output of the antenna 3 toward the human head portion A.

In the portable telephone according to this embodiment, the ground electrode pattern 2a of the circuit board 2 is present between a radiation path of electric waves transmitted from the antenna 3 and the human head portion A, although the antenna 3 is omnidirectional. Therefore, the ground electrode pattern 2a shields the human head portion A from the electric waves transmitted toward the same, thereby attenuating the transmission output toward the human head portion A. Thus, any influence exerted on the human body by the transmitted electromagnetic waves is reduced.

4

The ground electrode pattern 2a, which forms means for attenuating the transmission output toward the human head portion A as hereinabove described, must be so formed as to have a certain degree of area exceeding a region overlapping with the antenna 3 through the circuit board 2, as described above. Preferably, the ground electrode pattern 2a is formed to substantially cover the overall major surface of the circuit board 2 which is closer to the human head portion A.

The circuit board 2 is not restricted to that provided with the ground electrode pattern 2a on its one major surface as shown in FIG. 3, but may be replaced by a multilayer circuit board which contains such a ground electrode pattern 2a. Further, the ground electrode pattern 2a may alternatively be formed on the major surface of the circuit board 2 on which the antenna 3 is mounted. Namely, the ground electrode pattern 2a can be formed in any arbitrary position so far as the same is interposed in the radiation path of the electric waves which are transmitted from the antenna 3 toward the human head portion A, so that the same can reduce the transmission output toward the human head portion A in any case.

The antenna 3 is properly formed by a miniature surface mounted type antenna which can be easily arranged in proximity to the ground electrode pattern 2a, in order to improve the electromagnetic shielding effect of the ground electrode pattern 2a. An example of such a surface mounted type antenna is now described with reference to FIGS. 4A and 4B.

FIG. 4A is an exploded perspective view of an antenna 3, and FIG. 4B is a perspective view of the antenna 3. This antenna 3 is formed by stacking a dielectric substrate 6 provided with an antenna pattern 4 consisting of a conductive material, a dielectric substrate 7 provided with a shield pattern 5 consisting of a conductive material, a dummy substrate 8 provided with no electrode, and protective substrates 9A and 9B, and forming a plurality of external electrodes 10 on side surfaces of the laminate as formed. While this antenna 3 is normally omnidirectional, FIG. 5 shows a directional pattern of this antenna 3 when it is built in the aforementioned communicator body 1. Referring to FIG. 5, a line of  $-180^\circ$  shows the direction of the human head portion A, as clearly understood from FIG. 3. Thus, it is clearly understood from the directional pattern shown in FIG. 5 that the output is attenuated by at least 10 dB in the direction of the human head portion A in the portable telephone according to this embodiment employing the aforementioned antenna 3. Thus, it is understood possible to reduce the transmission output to not more than  $1/10$  in the direction of the human head portion A.

FIG. 6 is a partially fragmented perspective view showing another exemplary antenna 17 which is employable for the portable telephone according to the first embodiment of the present invention. The antenna 17 shown in FIG. 6 has a multilayer substrate 11 consisting of a dielectric substance or synthetic resin. An input/output electrode 12 is formed on a side surface of the multilayer substrate 11. This input/output electrode 12 is connected to a lead electrode 13 which is formed in the multilayer substrate 11 to reach its central portion. An external electrode 14 is formed on another side surface of the multilayer substrate 11 which is perpendicular to that provided with the input/output electrode 12. Further, a metal cap 15 forming a transmission/receiving part is mounted on an upper surface of the multilayer substrate 11, and a coil-shaped metal wire 16 is connected between the lead electrode 13 and the metal cap 15.

FIG. 7 is a perspective view showing still another exemplary antenna 21 which is employable for the portable



5

telephone according to the first embodiment of the present invention. The antenna 21 shown in FIG. 7 is formed by combining a multilayer dielectric substrate 19 which is provided with a plurality of external electrodes 18 on its side surface and a metal cap 20 forming a transmission/receiving part with each other.

As clearly understood from the antennas 17 and 21 shown in FIGS. 6 and 7, the structure of the antenna which is employed for the portable telephone according to the first embodiment of the present invention is not particularly restricted. In the antennas 17 and 21, the transmission/receiving parts are formed by the metal caps 15 and 20 which are excellent in conductivity, whereby Joule loss is reduced and hence it is possible to improve the gains of the antennas 17 and 21.

FIG. 8 is a partially fragmented front sectional view showing a state of employment of a mobile communicator according to a second embodiment of the present invention. The second embodiment is also applied to a portable telephone.

However, it is pointed out here that the present invention is also applicable to a mobile communicator other than a portable telephone, such as an on-vehicle mobile communicator, for example.

Referring to FIG. 8, the portable telephone according to this embodiment has a portable telephone body 31 having a case which is substantially in the form of a rectangular parallelepiped. One major surface of the portable telephone body 31 forms an outer surface part 31a which is on the side toward a human head portion A.

In the portable telephone body 31, a circuit board 32 is mounted in parallel with the outer surface part 31a, similarly to the first embodiment. A ground electrode pattern 32a is formed on one major surface of the circuit board 32, also similarly to the first embodiment. This ground electrode pattern 32a forms means for attenuating a transmission output of an antenna 33 described later toward the human head portion A, similarly to the first embodiment. The ground electrode pattern 32a is formed similarly to the ground electrode pattern 2a according to the first embodiment. This ground electrode pattern 32a may be built in the circuit board 32, or formed on a major surface of the circuit board 32 provided with the antenna

The antenna 33 is mounted on the major surface of the circuit board 32 which is opposite to the outer surface part 31a. Further, a whip antenna 34 is mounted on an upper portion of the portable telephone body 31. The whip antenna 34, which forms a second antenna according to the present invention, outwardly extends from the upper portion of the portable telephone body 31.

In the portable telephone according to this embodiment, the aforementioned antenna 33 is employed as a transmission antenna, while the whip antenna 34 is employed as a receiving antenna. Namely, a diversity unit is formed by the antenna 33 and the second antenna 34.

The aforementioned ground electrode pattern 32a is interposed between the transmission antenna 33 and the human head portion A. Therefore, the ground electrode pattern 32a electromagnetically shields the human head portion A from electric waves which are transmitted from the antenna 33. Also in the portable telephone according to this embodiment, therefore, the transmission output toward the human head portion A is attenuated by the ground electrode pattern 32a, whereby it is possible to reduce any influence on the human body.

On the other hand, the second antenna 34 for receiving can be formed by a proper antenna having higher sensitivity

6

which can attain excellent receiving performance with no substantial consideration of the aforementioned influence on the human body. Since the diversity unit is formed by the antenna 33 and the second antenna 34, it is possible not only to any influence on the human body exerted by electric waves in transmission but also to implement a portable telephone having high sensitivity and excellent receiving performance.

Antennas which are employable for the portable telephone according to the second embodiment of the present invention are now described with reference to FIGS. 9 to 12.

FIG. 9 is a partially fragmented perspective view showing an antenna 33, employable as the built-in antenna 33 in the second embodiment, which is surface-mounted on a circuit board 32. Referring to FIG. 9, employed is a dielectric substrate 41 consisting of ceramics or synthetic resin, which is in the form of a rectangular parallelepiped. Ground electrodes 42a and 42b are formed on both longer side surfaces of the dielectric substrate 41. Further, connecting electrodes 43a to 43c are formed on both shorter side surfaces of the dielectric substrate 41. In addition, a radiator 44 consisting of a metal such as copper or a copper alloy, for example, is fixed to the dielectric substrate 41.

The radiator 44, which is made of a material having low conductor loss such as the aforementioned metal, is provided with a radiating part 45 having a rectangular plane shape, and two fixed parts 46 and 47 downwardly bent from both shorter ends of the radiating part 45. A feed terminal 48 and a ground terminal 49 are integrally formed on a forward end of the fixed part 46. The fixed part 46 is made smaller in length than the fixed part 47 so that the distance between the radiating part 45 and the forward ends of the feed terminal 48 and the ground terminal 49 is equal to that between the radiating part 45 and the forward end of the fixed part 47. Further, the lengths of the fixed parts 46 including the feed terminal 48 and the ground terminal 49 and the fixed part 47 are set to be larger as compared with the thickness of the dielectric substrate 41.

When the radiator 44 is so mounted on the dielectric substrate 41 that the forward ends of the feed terminal 48, the ground terminal 49 and the fixed part 47 are flush with the lower surface of the dielectric substrate 41, therefore, a space X of a prescribed thickness is defined between the radiating part 45 and the upper surface of the dielectric substrate 41.

The aforementioned antenna 33 is assembled by inserting the dielectric substrate 41 in the radiator 44 so that the shorter side surfaces of the dielectric substrate 41 are brought into contact with inner sides of the fixed parts 46 and 47 and soldered thereto. Namely, the connecting electrode 43a of the dielectric substrate 41 and the fixed part 47 of the radiator 44 as well as the connecting electrodes 43b and 43c provided on the dielectric substrate 41 and the feed and ground terminals 48 and 49 of the radiator 44 are bonded to each other by solder while defining the space X between the radiating part 45 and the upper surface of the dielectric substrate 41, thereby forming the antenna 33.

The antenna 33 is placed on the circuit board 32, and the ground electrodes 42a and 42b and the ground terminal 49 are soldered to a ground electrode pattern 32c which is formed on the circuit board 32 while the feed terminal 48 is soldered to a feeder 32b provided on the circuit board 32, so that the antenna 33 is surface-mounted on the circuit board 32.

In the printed circuit board 32, the aforementioned ground electrode pattern 32a is formed substantially over its lower surface.

In the aforementioned antenna 33, a high-frequency current flowing in the radiating part 45 of the radiator 44 flows from the feed terminal 48 to a side surface which is opposed to that provided with the feed terminal 48, as shown by a schematic plan view in FIG. 10. A magnetic field is generated around the high-frequency current and an electric field is generated around the magnetic field, whereby the radiating part 45 radiates electric waves. Due to the space X defined between the radiating part 45 of the radiator 44 and the upper surface of the dielectric substrate 45, an eddy current generated on a ground plane by the magnetic field is so suppressed that the electric field hardly concentrates in the interior of the dielectric substrate 41. Thus, radiation efficiency for the electric waves is improved and the gain of the antenna 33 is improved, so that a sufficient gain can be ensured even when the antenna 33 is miniaturized.

Since the radiating part 45 for transmitting/receiving electric waves is made of a metal, an electric resistance component of the antenna 33 is reduced while its heat capacity is increased. Thus, Joule loss is so reduced that the gain of the antenna 33 is improved also by this.

The ground electrodes 42a and 42b, the feed terminal 48 and the ground terminal 49 are formed on the side surfaces so that the dielectric substrate 41 has a flat bottom surface, whereby the antenna 33 can be easily surface-mounted on the circuit board 32.

A sample of the aforementioned antenna 33 was prepared to have a length of 10 mm, a width of 6.3 mm and a height of 4 mm with a resonance frequency of 1.9 GHz, and surface-mounted on the portable telephone according to the second embodiment of the present invention, to be subjected to measurement of its directional pattern. FIG. 11 shows the result. As shown in FIG. 11, this sample exhibited an excellent value of the maximum gain of -1 dB, and hence it is understood possible to attain a high gain in a miniature antenna. Further, the gain is attenuated by at least 10 dB in the -180° direction, i.e., the direction toward the human head portion A, and hence it is understood possible to reduce the transmission output toward the human head portion A to not more than 1/10.

FIG. 12 is a perspective view for illustrating the structure of another antenna 53 which is employed in place of the aforementioned antenna 33. The antenna 53 shown in FIG. 12 has a dielectric substrate 61 consisting of synthetic resin or dielectric ceramics, and a radiator 64 consisting of a material having low conductor loss. The material having low conductor loss can be prepared from a metal such as copper or a copper alloy, similarly to that in the aforementioned antenna 33.

The dielectric substrate 61 is provided on its both longer side surfaces with ground electrodes 62 (FIG. 12 shows only the ground electrode 62 provided on one side surface). Further, connecting electrode 62c is formed on one shorter side surface. In addition, a single connecting electrode is formed on another shorter side surface (not shown). Namely, the dielectric substrate 61 is substantially similar in structure to the dielectric substrate 41 shown in FIG. 9.

This antenna 53 is different from the antenna 33 in the structure of the radiator 64. The radiator 64 is provided with a radiating part 65 having a rectangular plane shape. Shorter side edges of the radiating part 65 are downwardly bent to form first and second fixed parts 66 and 67. The fixed part 67 is bonded to the connecting electrode (not shown) which is formed on the shorter side surface of the dielectric substrate 61 by solder. A feed terminal 68 and a ground terminal 69 are integrally formed on a forward end of the

fixed part 66. A slit 69a for serving as a solder injection part is formed in the ground terminal 69. This slit 69a is adapted to simplify injection of solder paste, so that the solder paste easily adheres to the connecting electrode 62c provided on the inner side. In more concrete terms, a solder discharge part of a dispenser is inserted in the slit 69a so that solder paste adheres to the connecting electrode 62c, and thereafter the solder paste is spread in a space between the ground terminal 69 and the connecting electrode 62c by heating, for enabling enlargement of the bonding area therebetween. The slit 69a may be replaced by a through hole which can receive the discharge part of the dispenser, thereby defining the solder injection part.

The feature of this embodiment resides in that stop members 64a to 64c are formed on both sides of the fixed parts 66 and 67, in order to form a space X of a prescribed thickness (the stop member provided on one side of the fixed part 67 is not shown in FIG. 12). Forward ends of the stop members 64a to 64c are brought into contact with the upper surface of the dielectric substrate 61, thereby deciding the thickness of the space layer X. Further, both longer side edges of the radiating part 65 are downwardly bent to form reinforcing members 64d for improving mechanical strength.

In the portable telephone according to the second embodiment of the present invention, it is also possible to employ the antenna 3, 17 or 21 which is employed for the portable telephone according to the first embodiment, in addition to the aforementioned antenna 33 or 53. On the other hand, it is also possible to apply the antenna 33 or 53, which is employed for the second embodiment, to the portable telephone according to the first embodiment. Namely, the structure of the built-in antenna is not restricted in particular according to the present invention.

Although the present invention has been described and illustrated in detail, it is clearly understood that the same is by way of illustration and example only and is not to be taken by way of limitation, the spirit and scope of the present invention being limited only by the terms of the appended claims.

What is claimed is:

1. A movable communicator comprising:

a communicator body having an outer surface part for being brought into contact with or close to a portion of a human head during use of said movable communicator;

a circuit board in said communicator body and an antenna mounted on a surface of said circuit board on a side thereof opposite to said outer surface part; and

means arranged between said outer surface part of said communicator body and said antenna, for attenuating a transmission output of said antenna toward said human head portion, said means comprising a ground pattern on said circuit board between said antenna and said outer surface part.

2. A movable communicator in accordance with claim 1, wherein said antenna comprises a multilayer dielectric substance having an antenna pattern and a shield pattern.

3. A movable communicator in accordance with claim 1, wherein said antenna has a transmission/receiving part which includes a metal cap.

4. A movable communicator in accordance with claim 1, wherein said antenna comprises:

a dielectric substrate,

a ground electrode on at least one of a side surface and a bottom surface of said dielectric substrate,

9

a radiator comprised in a laminate together with said dielectric substrate, said radiator comprising a material having low conductor loss, said radiator being fixed to said dielectric substrate so that one major surface thereof is opposed to one major surface of said dielectric substrate, and

a feed part on at least one of a side surface and a bottom surface of said laminate formed by said dielectric substrate and said radiator.

5. A movable communicator in accordance with claim 4, wherein said radiator comprises a radiating part having said one major surface, and at least one fixed part extending from at least one side edge of said radiating part toward said dielectric substrate,

said at least one fixed part being fixed to said side surface of said dielectric substrate, thereby fixing said radiator to said dielectric substrate.

6. A movable communicator in accordance with claim 5, wherein said one major surface of said radiating part of said radiator is opposed to said one major surface of dielectric substrate through a space layer having a predetermined thickness.

7. A movable communicator in accordance with claim 6, wherein said antenna further comprises a feed terminal and a ground terminal integrally formed on a forward end of at least one of said fixed parts.

8. A movable communicator in accordance with claim 7, wherein a pair of stop members are arranged on sides of at least one said fixed part so that forward ends of said pair of stop members are brought into contact with said one major surface of said dielectric substrate, thereby determining said thickness of said space layer.

9. A movable communicator in accordance with claim 1, further comprising:

a second antenna for receiving, mounted on said communicator body so as to outwardly extend from said communicator body,

wherein said antenna which is built in said communicator body is employed as a transmission antenna, whereby said transmission antenna, and said second antenna for receiving, together form a diversity unit.

10. A movable communicator in accordance with claim 9, wherein said means for attenuating said transmission output toward said human head portion is a circuit board having a ground pattern which is arranged between said antenna and said outer surface.

10

11. A movable communicator in accordance with claim 10, wherein said antenna is surface-mounted on a surface of said circuit board opposite to said outer surface part.

12. A movable communicator in accordance with claim 11, wherein said antenna comprises a multilayer dielectric substance having an antenna pattern and a shield pattern.

13. A movable communicator in accordance with claim 11, wherein said antenna has a transmission/receiving part which includes a metal cap.

14. A movable communicator in accordance with claim 9, wherein said antenna comprises:

a dielectric substrate,

a ground electrode on at least one of a side surface and a bottom surface of said dielectric substrate,

a radiator comprised in a laminate together with said dielectric substrate, said radiator comprising a material having low conductor loss, said radiator being fixed to said dielectric substrate so that one major surface thereof is opposed to one major surface of said dielectric substrate, and

a feed part on at least one of a side surface and a bottom surface of said laminate formed by said dielectric substrate and said radiator.

15. A movable communicator in accordance with claim 14, wherein said radiator comprises a radiating part having said one major surface, and at least one fixed part extending from at least one side edge of said radiating part toward said dielectric substrate,

said at least one fixed part being fixed to said side surface of said dielectric substrate, thereby fixing said radiator to said dielectric substrate.

16. A movable communicator in accordance with claim 15, wherein said one major surface of said radiating part of said radiator is opposed to said one major surface of dielectric substrate through a space layer having a predetermined thickness.

17. A movable communicator in accordance with claim 16, wherein said antenna further comprises a feed terminal and a ground terminal integrally formed on a forward end of at least one of said fixed parts.

18. A movable communicator in accordance with claim 17, wherein a pair of stop members are arranged on sides of at least one said fixed part so that forward ends of said pair of stop members are brought into contact with said one major surface of said dielectric substrate, thereby determining said thickness of said space layer.

\* \* \* \* \*

Appendix D



US005542106A

**United States Patent** [19]  
**Krenz et al.**

[11] **Patent Number:** **5,542,106**  
[45] **Date of Patent:** **Jul. 30, 1996**

[54] **ELECTRONIC DEVICE HAVING AN RF CIRCUIT INTEGRATED INTO A MOVABLE HOUSING ELEMENT**

*Primary Examiner—Andrew Faile*  
*Assistant Examiner—Philip J. Sobutka*  
*Attorney, Agent, or Firm—Kirk W. Dailey; Randall S. Vaas*

[75] **Inventors:** Eric L. Krenz, Crystal Lake; James P. Phillips, Lake in the Hills, both of Ill.

[57] **ABSTRACT**

[73] **Assignee:** Motorola, Inc., Schaumburg, Ill.

When a radio frequency (RF) circuit is integrated into a movable housing element of an electronic device one must consider the affects of the surrounding area when the RF circuit is in a functioning position. A preferred embodiment is a radiotelephone (100) having an antenna (105) integrated into a movable housing element (101). The antenna (105) has two functioning positions, an opened and a closed position. The antenna (105) is tuned for efficiency when the movable housing element (101) is in the opened position. When the movable housing element (101) is in the closed position, a first pair of conductive plates (107, 109) located in the movable housing element (101) and a second conductive plate (113) located in the second housing element (103) are positioned to retune the antenna (105) due to the detuning affects caused by the close proximity of other electronic components located in the second housing element (103).

[21] **Appl. No.:** 306,357

[22] **Filed:** Sep. 15, 1994

[51] **Int. Cl.<sup>6</sup>** ..... H04B 01/38

[52] **U.S. Cl.** ..... 455/90; 455/129; 455/289; 455/347; 343/702

[58] **Field of Search** ..... 455/90, 89, 129, 455/289, 290, 347, 121; 343/702, 861; H01Q 1/24

[56] **References Cited**

**U.S. PATENT DOCUMENTS**

4,992,799	2/1991	Gavay	343/702
5,170,173	12/1992	Krenz et al.	455/347 X
5,335,368	8/1994	Tamura	455/90
5,337,061	8/1994	Pye et al.	343/702

**7 Claims, 2 Drawing Sheets**

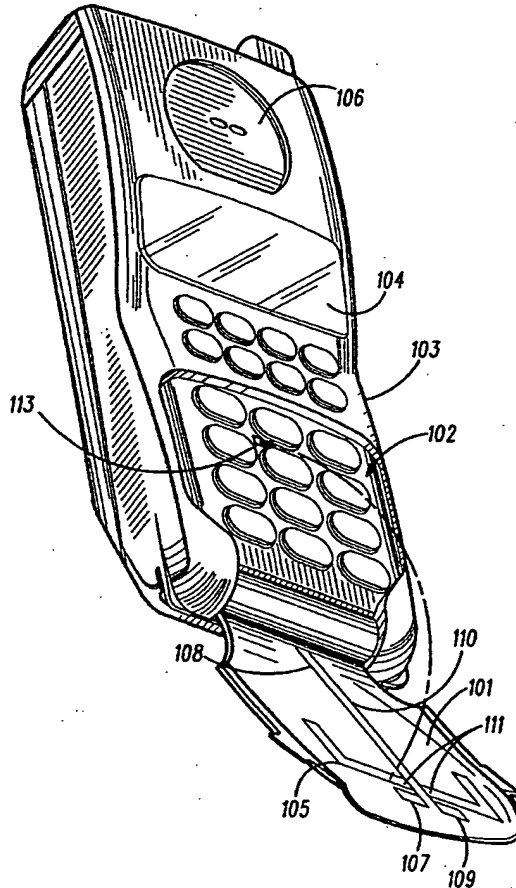

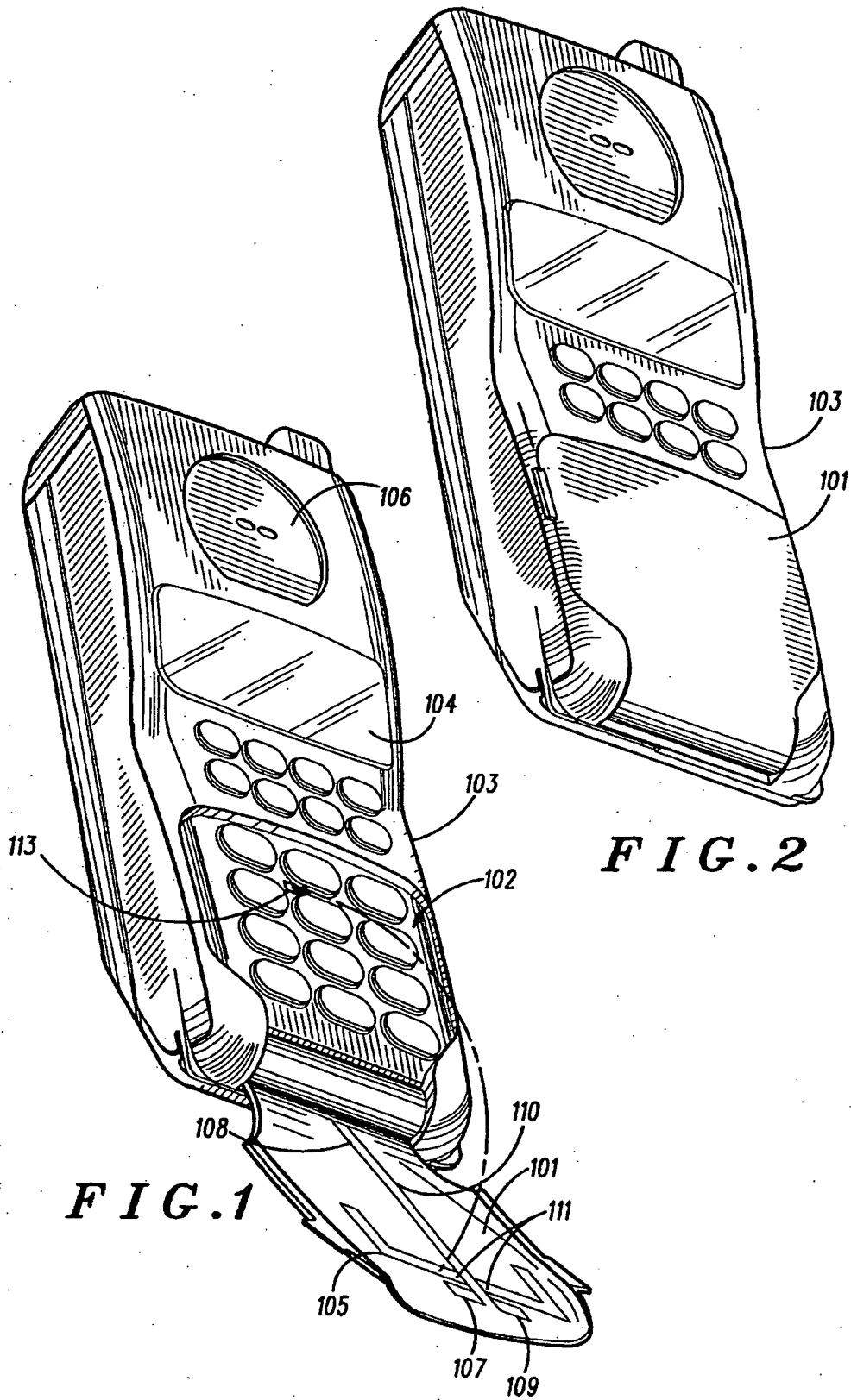

*FIG. 3*

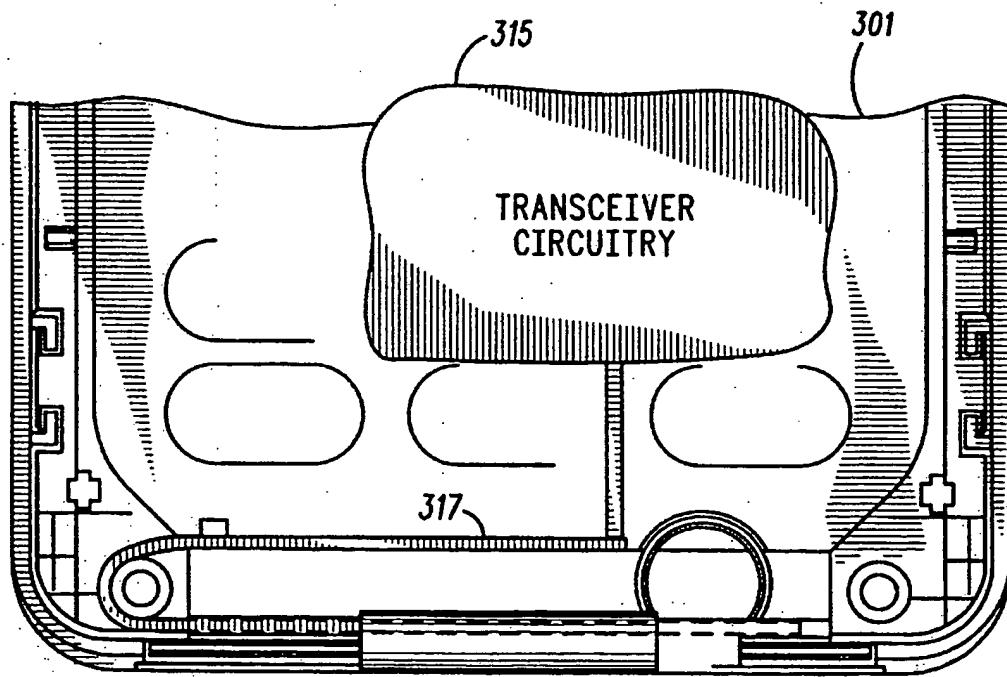

## ELECTRONIC DEVICE HAVING AN RF CIRCUIT INTEGRATED INTO A MOVABLE HOUSING ELEMENT

### FIELD OF THE INVENTION

Generally, this invention relates to radio frequency (RF) circuits, including antennas, and more specifically to integrating those RF circuits into a movable housing element of an electronic device.

### BACKGROUND OF THE INVENTION

Generally, electronic devices, such as portable radios, are becoming physically smaller and customers and manufacturers are demanding more features. Consequently, some radios require a compact integrated antenna to provide either a second antenna for diversity or to conceal the primary antenna for cosmetic purposes.

Since most of the surface area of a portable radio is normally obstructed by a user's hand, a logical location for an integrated antenna is in an extended portion of the radiotelephone housing. This extended housing may be realized by rotating a keypad cover outwards, by twisting a portion of the radiotelephone housing, or by sliding a portion of the radiotelephone housing from a first position to a second position. Such a portable radio has valid modes of operation when the housing element is in the first position as well as in the second position.

Consequently, any antenna or RF circuit designed to be integrated into a movable housing element must be designed such that it performs well in both in the first position and the second position. A difficulty in the antenna design arises when the antenna in the second position is in close proximity to the electrical components of the portable radio and the antenna in the first position is further away from the inner components of the radio. Typically, an antenna must be tuned to match the impedance of the power amplifier for maximum performance of the antenna. The matching of an antenna is highly dependent upon the position of the antenna during its operation. Here, the antenna has two physical positions in which it must operate efficiently. If the antenna is tuned when in the first position, then when the antenna is in the second position, near the electrical components of the transceiver, the antenna is detuned. A detuned antenna has a poor impedance match to the power amplifier and suffers a substantial loss of performance. Thus, it is necessary to develop an antenna that functions efficiently when the movable housing element is in the first position and in the second position.

### BRIEF DESCRIPTION OF THE DRAWINGS

FIG. 1 is an illustration of a radiotelephone having a movable housing element in an opened position in accordance with the present invention.

FIG. 2 is an illustration of the radiotelephone illustrated in FIG. 1 with the movable housing element in a closed position in accordance with the present invention.

FIG. 3 is an illustration of a portion of the radiotelephone of FIG. 1 in accordance with the present invention.

### DESCRIPTION OF THE PREFERRED EMBODIMENT

FIG. 1 is an illustration of a preferred embodiment of the present invention. Here, an antenna system is integrated into a portable radiotelephone 100 such as a 1.9 GHz Japan

pocket phone available from Motorola, Inc. A portable radiotelephone typically includes a keypad 102, a display 104, a speaker 106, a microphone (not shown) as well as the radiotelephone's electronic components. The radiotelephone 100 is part of a radio telephone system that uses radio frequency signals to communicate between a remote transceiver (not shown) and a plurality of radiotelephones, such as the radiotelephone 100 illustrated in FIG. 1. An antenna is used to send and receive radio frequency signals between the remote transceiver and the radiotelephone. As discussed in the background, it is desirable to provide an antenna integrated into an extendible portion of the radiotelephone's housing.

Here, the housing of the radiotelephone 100 is separated into a first housing element 101 and a second housing element 103. The first housing element 101, also referred to as a keypad cover, is movable with respect to the second housing element 103. The second housing element 103 contains a substantial portion of the portable radiotelephone's electronic components. It is foreseeable that the present invention could be embodied in other radio apparatus where the first housing element is moved between the first position and the second position using a twisting motion, a rotating motion, or a sliding motion. FIG. 2 is an illustration of the radiotelephone 100 of FIG. 1 with the first movable housing element 101 in a closed, or second position.

In the preferred embodiment, the antenna system includes an antenna 105 disposed within the first movable housing element 101, a first pair of conductive plates 107, 109 disposed within the first movable housing element 101 and located at a feed point 111 of the antenna 105. Conductive plate 107 is electrically coupled to a first terminal 108 of the antenna 105, and conductive plate 109 is electrically coupled to a second terminal 110 of the antenna 105. In the preferred embodiment the antenna 105 is a half-wave dipole, however, other antennas could be substituted such as a loop antenna, a patch antenna, or a monopole antenna, or any other known antenna. Regardless of the type of antenna, the first pair of conductive plates 107, 109 are disposed at the feed point for the antenna 105. Here, the feed point 111 of the dipole is located as shown in FIG. 1. A second conductive plate 113 is disposed within the second housing element 103 as shown in FIG. 1. The conductive plates 107, 109 and 113 add shunt capacitance to the antenna system. Alternatively, the shunt load capacitance created by the conductive plates may be shifted away from the immediate feed point of the antenna. A very wide range of antenna impedance can be matched by changing the size of the capacitive plates and their location along the antenna or the transmission line in the flip that feeds the antenna.

FIG. 3 is an illustration of a portion of the radiotelephone 100 of FIG. 1. Specifically, FIG. 3 is used to illustrate a connection between the antenna 105 and a transceiver 315 via a transmission line 317. The transceiver 315 is a portion of the radiotelephone's electronic components. The antenna 105 is tuned to match the impedance of the transceiver 315 while the first movable housing element is in the open position, also referred to as the first position. When the first movable housing element 101 is in the first position, the first pair of conductive plates 107, 109 contribute only a small amount of shunt capacitance to the feed point impedance. This additional amount of shunt capacitance can be easily accounted for in the tuning of the antenna 105.

The second conductive plate 113 is positioned in the second housing element such that when the first movable housing element 101 is in the second position, the first pair



of conductive plates 107, 109 and the second conductive plate 113 are parallel to and in very close proximity to each other. This parallel plate arrangement creates a substantial increase in the shunt capacitance across the antenna feed point 111. The increase shunt capacitance effectively retunes the antenna 105 to maintain maximum performance of the antenna 105 even though the antenna has been brought very close to the radiotelephone's electronic components.

When the antenna 105 is optimized with the first movable housing element 101 in the first position, as illustrated in FIG. 1, the antenna 105 is essentially tuned for free-space operation. When the first movable housing element 101 is in a second position, as illustrated in FIG. 2, it is close to the radiotelephone's electronics components. If dielectric is not present, image theory predicts with the first movable housing element in the second position the radiation resistance will drop and the antenna impedance will become dominated by capacitive reactance. In this case, adding shunt capacitance at the feed point will not compensate for the detuning affect caused by the radiotelephone's electronic components.

In the actual practice, when the first movable housing element 101 is in the second position, as illustrated in FIG. 2, the antenna 105 is not separated from the radiotelephone's electronic components by air, rather, they are separated by various dielectric layers created by the housing, keypad and display. These dielectric layers have dielectric constant which are greater than one. The presence of the higher dielectric material increases the effective electrical length of the antenna 105 when the first movable housing element 101 is in the second position, thus, causing the antenna impedance to become inductive rather than capacitive. Consequently, the addition of the shunt capacitance created by the conductive plates 107, 109, 113 rematches the antenna impedance to the transceiver's impedance. In other words, the shunt capacitance modifies the effective electrical length of the antenna 105 to equal the effective electrical length when the antenna 105 is in the first position. These effects have been verified by simulation and experiment as indicated in Tables 1-3.

Although the text of the preferred embodiment discusses the integration of an antenna into a movable housing element of a radiotelephone, the inventors envision their invention to be applicable to integrating any RF circuit into a movable housing element of an electronic device.

TABLE 1

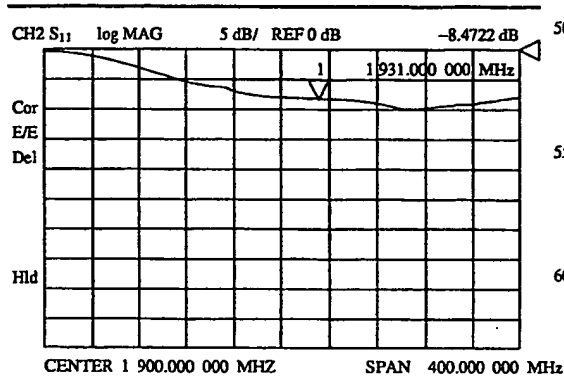

Return loss characteristic of the antenna in free space.

TABLE 2

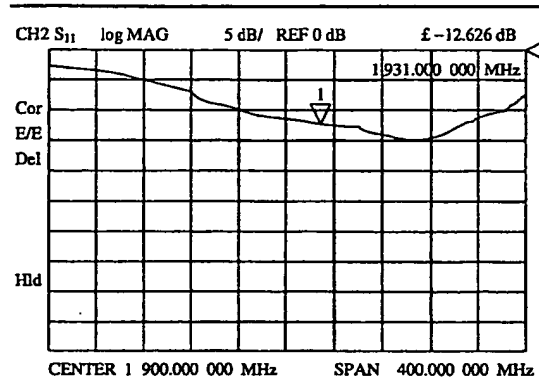

Return loss characteristic of the antenna in normal-use position near the user's head.

TABLE 3

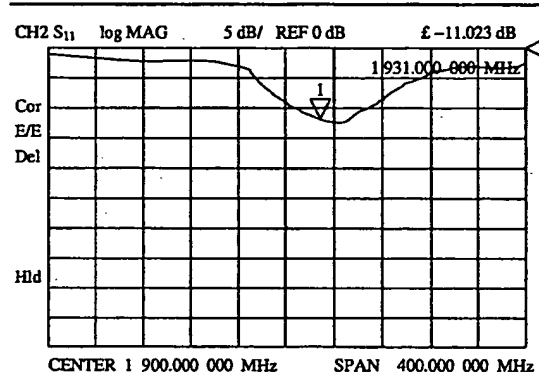

Return loss characteristic of the antenna in close proximity to the radio chassis (flip closed).

We claim:

1. An electronic device having a first housing element and a second housing element, where in the first housing element is movable between an open position and a closed position, the second housing element containing a substantial portion of the electronic device's electronic components, thereby creating a conductive body in the second housing element, the electronic device comprising:

- an antenna having an impedance disposed within the first housing element;
- a first conductive plate disposed within the first housing element and being coupled to the antenna; and
- a second conductive plate disposed within the second housing element and positioned such that when the first housing element is in the open position the second conductive plate has a minimal effect on the impedance of the antenna and when the first housing element is in the closed position the second conductive plate is in close proximity to the first conductive plate thereby effecting the impedance of the antenna to counteract any effect on the impedance of the antenna caused by the conductive body whereby the antenna in the first housing element is tuned for use with the electronic circuitry in both the open and closed positions of the electronic device.

5

2. An electronic device in accordance with claim 1 wherein said antenna is a dipole antenna.

3. An electronic device in accordance with claim 1 further including a third conductive plate disposed within the first housing element and coupled to said dipole antenna, said first and third conductive plates coupled to said second conductive plate when the device is in the closed position.

4. A radio having a first housing element and a second housing element, where in the first housing element is movable between a first open position and a second closed position, the second housing element containing a substantial portion of the radio's electronic components, thereby creating a conductive body in the second housing element, the radio comprising:

an antenna having an electrical length, a feed point and being disposed within the first housing element;

at least a first conductive plate disposed within the first housing element and coupled to the antenna; and

a second conductive plate disposed within the second housing element and positioned such that when the first housing element is in the first open position the second conductive plate has a minimal effect on the electrical length of the antenna and when the first housing element is in the second closed position the second conductive plate is in close proximity to the at least first conductive plate thereby capacitively coupling the first and second plates creating an effect on the electrical length of the antenna to counteract any effect on the electrical length of the antenna caused by the conductive body whereby the antenna in the first housing element is tuned for operation in both the open and closed positions.

5. A radio in accordance with claim 4 wherein said at least first conductive plate is connected to the feed point of the antenna.

6

6. A radio in accordance with claim 5 wherein said first antenna is a half-wave dipole antenna and further including a third conductive plate coupled to the feed point of the first antenna and capacitively coupled to the second conductive plate when the device is in the second closed position.

7. A radio communication device having a first housing element and a second housing element, the first housing element is movable between a first position and a second position, the second housing element containing a substantial portion of the radio communication device's electronic components, thereby creating a conductive body in the second housing element, the radio communication device comprising:

an antenna having a first impedance, a feed point, a first terminal, a second terminal and disposed within the first housing element;

a first pair of conductive plates disposed on the first terminal and the second terminal at the feed point of the antenna and within the first housing element; and

a second conductive plate disposed within the second housing element and positioned such that when the first housing element is in the first position the second conductive plate has a minimal effect on the impedance of the antenna and when the first housing element is in the second position the second conductive plate is in close proximity to the first pair of conductive plates creating an effect on the impedance of the antenna to counteract any effect that the conductive body has on the impedance of the antenna.

\* \* \* \* \*

# Appendix E



US005400040A

# United States Patent [19]

[11] Patent Number: **5,400,040**

Lane et al.

[45] Date of Patent: **Mar. 21, 1995**

- [54] MICROSTRIP PATCH ANTENNA
- [75] Inventors: Jeffrey P. Lane, Haverhill; Joseph P. Biondi, N. Andover, both of Mass.; Joseph S. Pleva, Londonderry, N.H.
- [73] Assignee: Raytheon Company, Lexington, Mass.
- [21] Appl. No.: 54,377
- [22] Filed: Apr. 28, 1993
- [51] Int. Cl.<sup>6</sup> ..... H01Q 1/38
- [52] U.S. Cl. .... 343/700 MS; 343/822; 343/873
- [58] Field of Search ..... 343/822, 846, 873, 700 MS; H01Q 1/38

G. Kumer, et al., IEEE Transactions on Antennas and Propagation, vol. AP-33, No. 2, pp. 173-178, Feb. 1985.

Primary Examiner—Donald Hajec  
Assistant Examiner—Steven Wigmore  
Attorney, Agent, or Firm—Donald F. Mofford

### [57] ABSTRACT

A patch radiator antenna is described including a sheet of conductive material and a dielectric substrate having a first and second surface, the sheet of conductive material disposed upon the first surface of the dielectric substrate. The patch radiator antenna further includes a plurality of patch radiator elements disposed upon the second surface of the dielectric substrate, each one of the plurality of patch radiator elements having sides with a width and a length. The plurality of patch radiator elements include a first patch radiator element having a feed probe to couple the first patch radiator element to an RF signal source and at least one second patch radiator element including a microstrip feed along the width of the patch radiator element, the at least one second patch radiator element disposed fore of the first patch radiator element. The patch radiator antenna further includes a strip conductor having a first end and a second end, the first end connected to the microstrip feed and the second end connected along the length of the first patch radiator element. With such an arrangement, a corporate feed for each patch radiator element is eliminated, thus reducing feed line radiation.

### [56] References Cited

#### U.S. PATENT DOCUMENTS

3,947,850	3/1976	Kaloi .....	343/822 X
4,072,951	2/1978	Kaloi .....	343/846 X
4,686,535	9/1987	Lalezari .....	343/700 MS X
4,816,836	3/1989	Lalezari .....	343/873 X
4,893,129	1/1990	Kodera et al. ....	343/700 MS X
4,907,006	3/1990	Nishikawa et al. ....	343/700 MS X
4,924,236	5/1990	Schuss et al. ....	343/700 MS X
5,008,681	4/1991	Cavallaro et al. ....	343/700 MS X
5,231,407	7/1993	McGirr et al. ....	343/700 MS X
5,337,066	8/1994	Hirata et al. ....	343/700 MS X

#### OTHER PUBLICATIONS

"Nonradiating Edges and Four Edges Gap-Coupled Multiple Resonator Broad-Band Microstrip Antennas,"

16 Claims, 6 Drawing Sheets

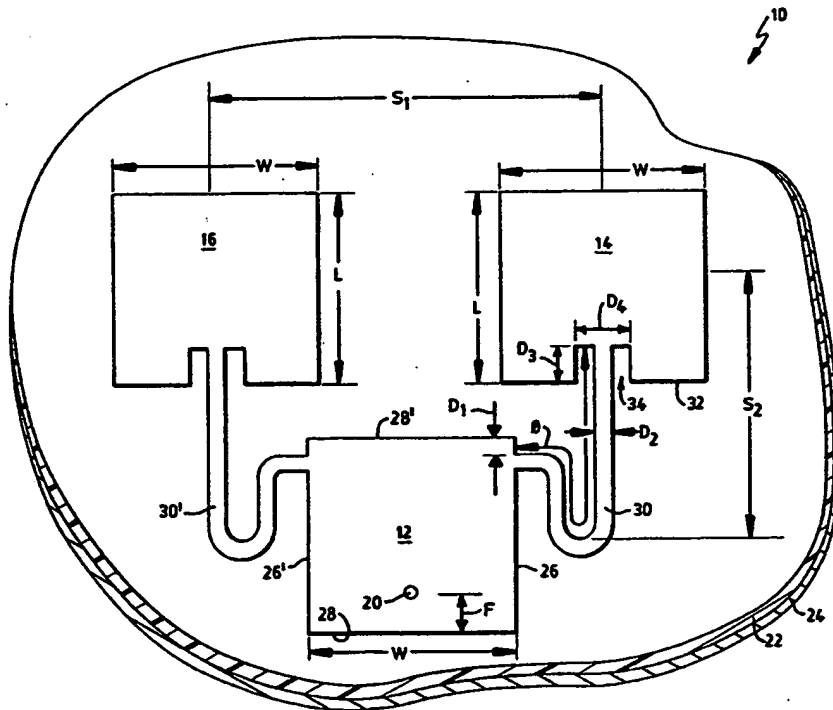

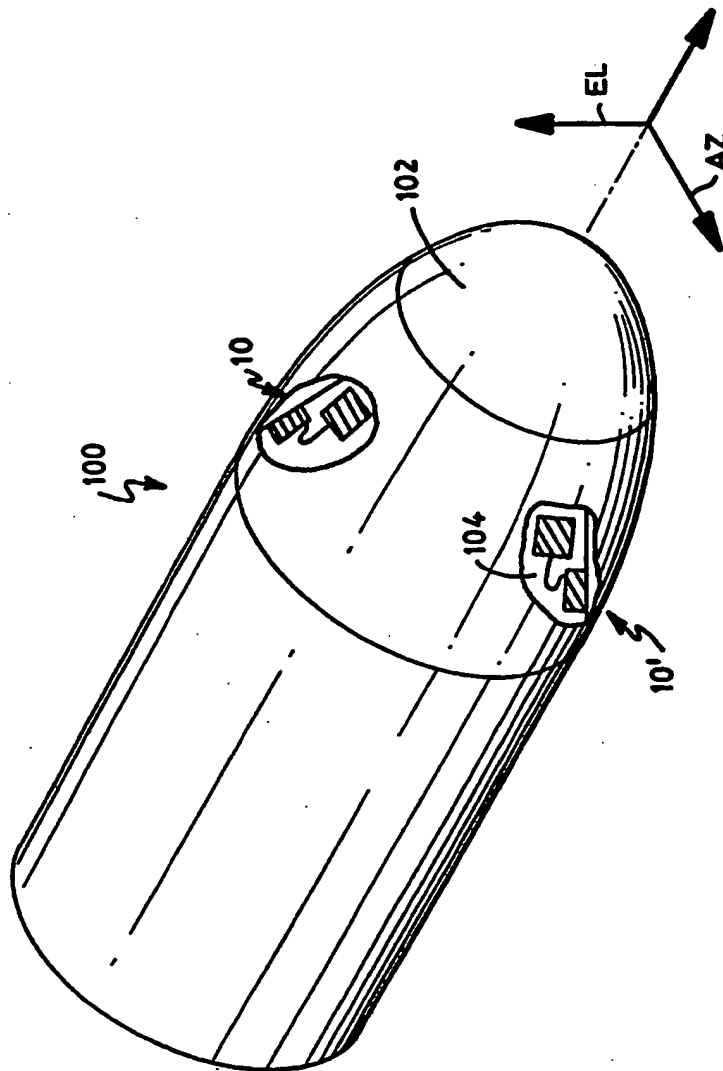

FIG. 1

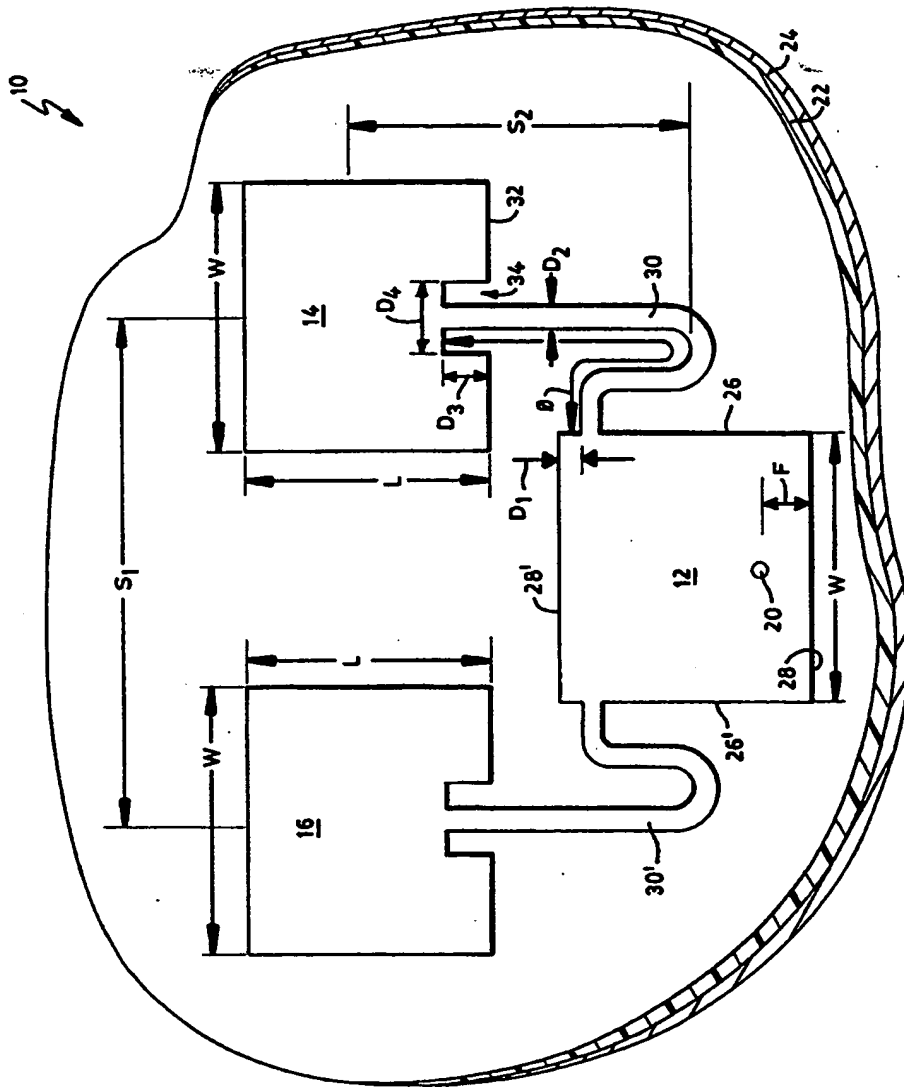

FIG. 2

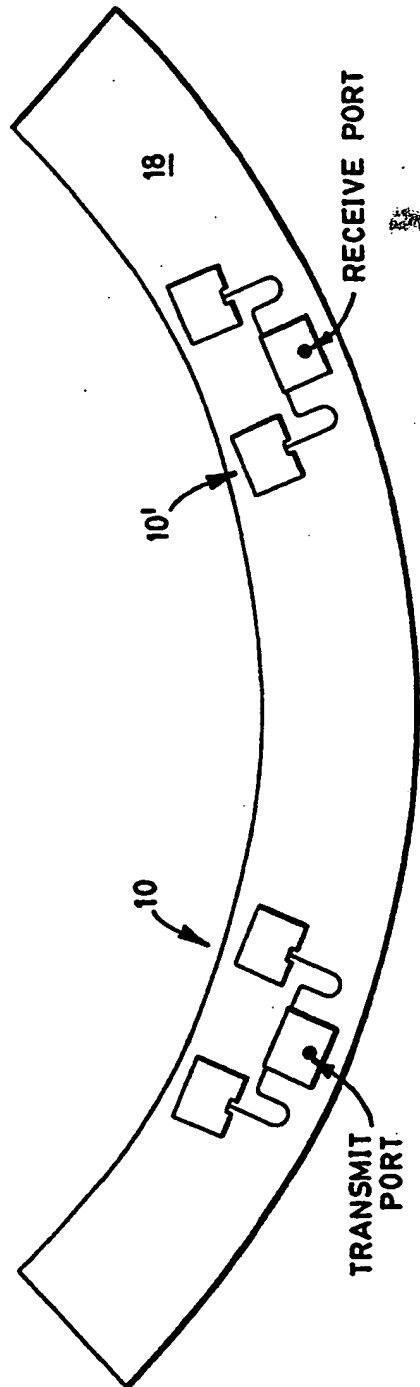

FIG. 3A

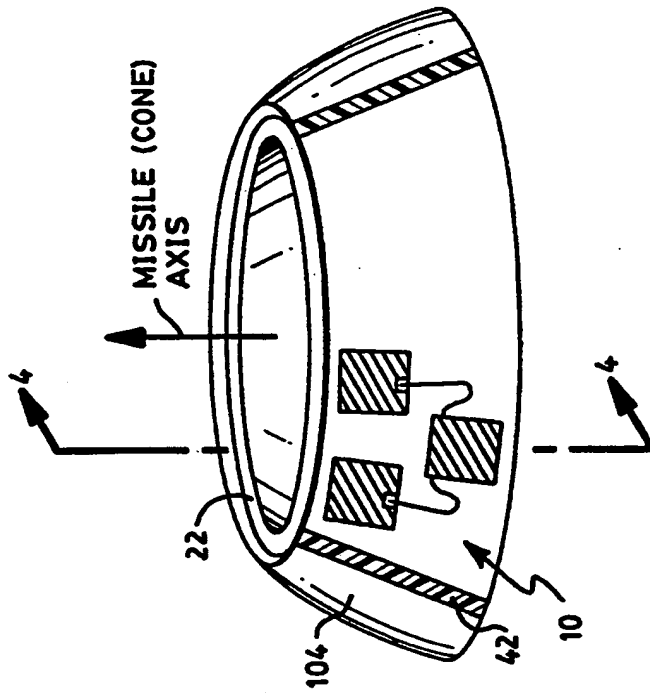

FIG. 3

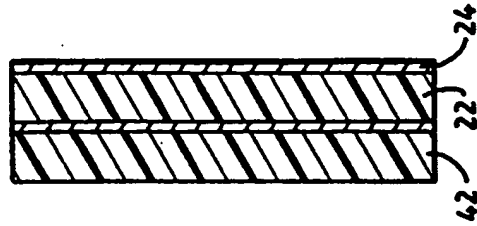

FIG. 4



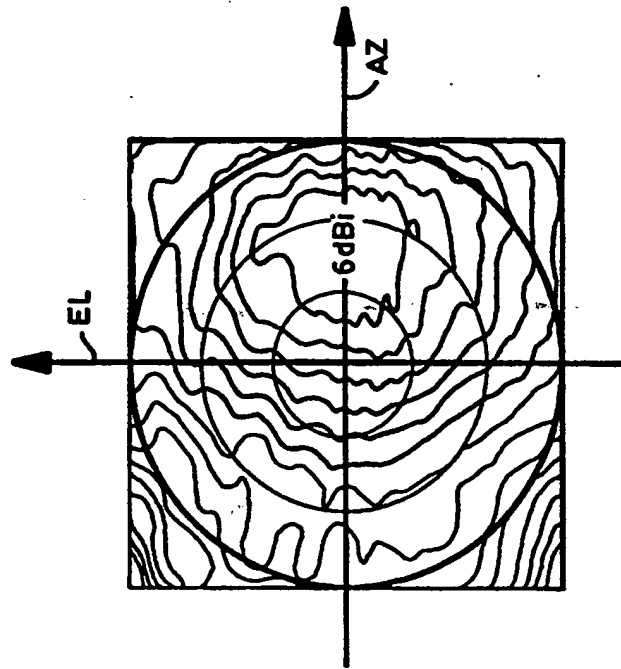

FIG. 5B

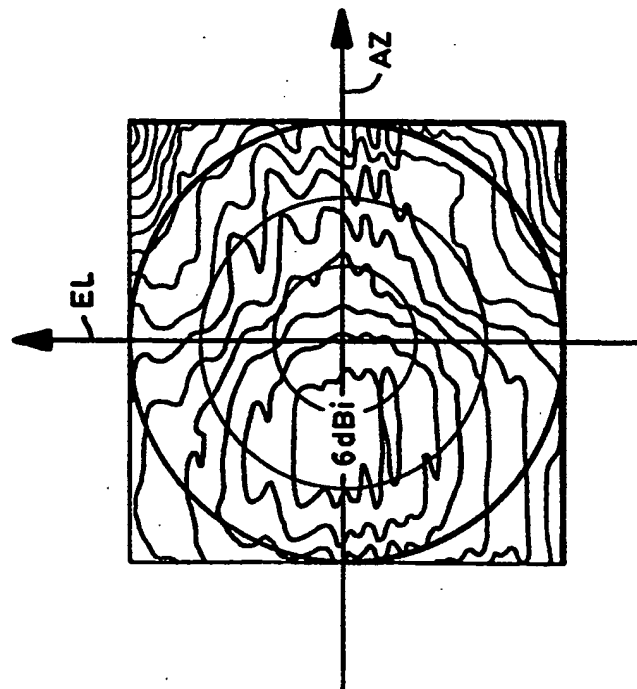

FIG. 5A

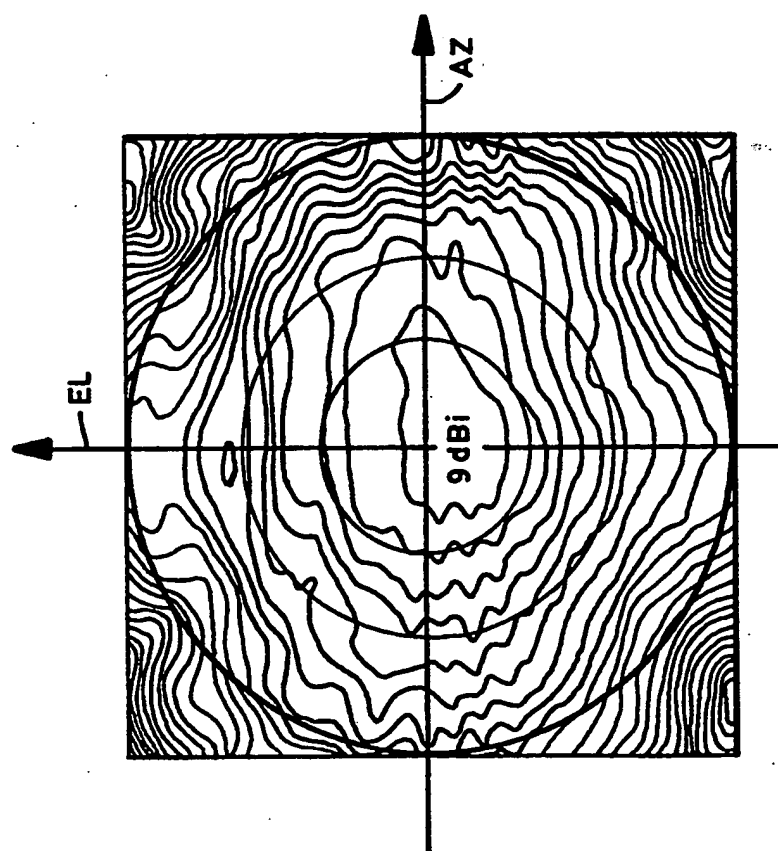

FIG. 5C

## MICROSTRIP PATCH ANTENNA

This invention was made with Government support under Contract No. DAAH01-91-C-A017 awarded by the Department of the Army. The Government has certain rights in this invention.

### BACKGROUND OF THE INVENTION

This invention relates to patch antennas and more particularly to directional patch antennas wherein multiple patch radiators are used to control the direction of a beam of radio frequency (RF) energy from the antenna.

In missile applications, antennas are often required to be mounted conformally with the generally cylindrical shape of a missile. Antennas which adapt easily to conformal mounting usually produce a beam of RF energy having a main lobe directed normally (or broadside to) the missile. In some applications, the required direction of the main lobe of the beam of RF energy is in a direction along an axis of the missile. To provide the latter, known patch antennas either include elements which are parasitically fed or corporate feeds to provide the RF energy to each patch element. A corporate feed includes components that occupy critical area internal to the missile. The mass and volume of all components within the missile are critical to the performance of the missile and any decrease in the size and number of components is highly desirable.

### SUMMARY OF THE INVENTION

With the foregoing background in mind, it is an object of this invention to provide a patch antenna easily mounted on a side of a missile while providing a beam of RF energy having a main lobe along the axis of the missile.

Another object of this invention is to provide a patch antenna with less components.

The foregoing and other objects of this inventions are met generally by a patch radiator antenna including a sheet of conductive material and a dielectric substrate having a first and second surface, the sheet of conductive material disposed upon the first surface of the dielectric substrate. The patch radiator antenna further includes a plurality of patch radiator elements disposed upon the second surface of the dielectric substrate, each one of the plurality of patch radiator elements having sides with a width and a length. The plurality of patch radiator elements include a first patch radiator element having a feed probe to couple the first patch radiator element to an RF signal source and at least one second patch radiator element including a microstrip feed along the width of the patch radiator element, the at least one second patch radiator element disposed fore of the first patch radiator element. The patch radiator antenna further includes a strip conductor having a first end and a second end, the first end connected to the microstrip feed and the second end connected along the length of the first patch radiator element. With such an arrangement, a corporate feed for each patch radiator element is eliminated, thus reducing feed line radiation.

In accordance with another aspect of the present invention, a patch radiator antenna includes a first patch radiator having a pair of edges and a technique for providing an image patch radiator element in front of the first patch radiator for providing a desired end fire excitation. The technique includes a second patch radiator

having a microstrip feed, the second patch radiator disposed fore of the first patch radiator and a third patch radiator having a microstrip feed, the third patch radiator also disposed fore of the first patch radiator. The technique includes coupling a portion of RF energy propagating therethrough between the first patch radiator and the second patch radiator and between the first patch radiator and the third patch radiator including a first strip conductor having a first end and a second end, the first end connected to the first patch radiator along one of the edges and the second end connected to the microstrip feed of the second patch radiator and a second strip conductor having a first end and a second end, the first end connected to the first patch radiator along a different one of the edges and the second end connected to the microstrip feed of the third patch radiator. With such an arrangement, an apparent image patch is provided to simulate a two element linear array to provide the desired end fire directivity. When using two patch radiator elements disposed juxtapositional with each other to provide a linear array, such an arrangement produced excessive mutual coupling which inhibited the required directivity. The above described arrangement provides the required directivity by reducing mutual coupling among adjacent patch radiator elements and with less feed lines required, reduces feed line radiation.

### BRIEF DESCRIPTION OF THE DRAWING

For a more complete understanding of this invention, reference is now made to the following description of the accompanying drawings, wherein:

FIG. 1 is a sketch of an fore portion of a missile showing the contemplated location of a patch radiator antenna according to the invention;

FIG. 2 is a plan view of the patch radiator antenna according to the invention;

FIG. 3 is an isometric view of the patch radiator antenna disposed on a substrate partially torn away;

FIG. 3A is a plan view of a transmit and a receive patch radiator antenna according to the invention disposed on a common membrane;

FIG. 4 is a cross-sectional view of the patch radiator antenna shown in FIG. 4 taken along the line 4A-4A; and

FIGS. 5A, 5B, and 5C are a sketch of relative signal strength about the axis of a missile provided by the patch radiator antennas, respectively, according to the invention.

### DESCRIPTION OF THE PREFERRED EMBODIMENTS

Referring now to FIG. 1, it may be seen that a missile 100 includes a fore portion (not numbered) wherein an infrared (IR) dome 102 is mounted. The IR dome 102 protects electronics (not shown) mounted behind the IR dome 102 while providing an aerodynamically enhanced shape to the missile 100. Also provided behind the IR dome 102 is a truncated conic ring 104 located aft of the IR dome 102 with a patch radiator antenna 10, here a transmit antenna at C-band, and a patch radiator antenna 10', here a receive antenna at C-band, disposed about the truncated conic ring 104. As described further hereinafter, the patch radiator antenna 10 and 10' are arranged to provide a forward looking beam for radio frequency (RF) energy in the direction forward of the missile 100. In the present application, the patch radiator antenna 10 and 10' are part of an altimeter system

wherein using radar doppler techniques, as the missile descends toward the ground, the height of the missile 100 is determined. It should be appreciated that the patch radiator antenna 10 and the patch radiator antenna 10' are similar in construction and the following description for the patch radiator antenna 10 is also applicable for the patch radiator antenna 10'. The patch radiator antenna 10 and the patch radiator antenna 10' provides a directional beam in a small circuit area and by disposing each antenna on opposite sides of the truncated cone 104, a nearly symmetric two way forward looking beam of RF energy is achieved.

Referring now to FIG. 2, the patch radiator antenna 10 as here contemplated is shown to include a plurality of patch radiator elements 12, 14 and 16 disposed on a dielectric substrate 22. The patch radiator elements 12, 14, and 16 are formed by depositing an electrically conducting material (here copper) in any conventional manner as shown. The patch radiator element (herein also referred to as a patch) 12 when actuated by itself, is operative to form a beamby reason of fringing fields around the periphery of such patch and the main lobe of such beam is broadside to such patch. Further, it will be observed that the patch 12, when matched to a feed, here coaxial line 20, is effectively equivalent to a resonant cavity. The coaxial line 20 in electrical contact with the patch 12 is passed through a dielectric substrate 22 and connected to a coaxial transmission line which couples RF energy (i.e. an RF signal) to requisite electronic circuitry (not shown). The outer shield of the coaxial transmission line is connected to a conductive sheet (i.e. ground plane) 24. It should be appreciated that the location of the connection of the coaxial line 20 does not affect the frequency of resonance, but the location does affect the input impedance of the patch radiator antenna 10 being described.

It should be appreciated that a patch has a constant impedance along the width  $W$  of the patch, but a changing impedance along the length  $L$  of the patch. Along an edge 26 having a length  $L$  of the patch 12, at the center of the edge 26, a low impedance exists with the impedance increasing when approaching an edge 28 or an edge 28'. The location of a connection point along the length of the patch 12 controls the resulting impedance of the connection point. Thus, the distance  $F$  being the distance from the edge 28 of the patch 12 to the center of the connection of the coaxial line 20 controls the input impedance of patch radiator antenna 10. In the present application, the distance  $F$  is approximately 0.0188 wavelengths of the RF energy propagating therethrough.

The patch radiator elements 12, 14 and 16 each have a length  $L$  here of approximately 0.2916 wavelengths of the RF energy propagating therethrough and a width  $W$  of approximately 0.3174 wavelengths of the RF energy propagating therethrough. The patch radiator antenna 10 further includes a strip conductor 30 having a first end connected to the patch 12 and a second end connected to the patch 14. The strip conductor 30 has a width  $D_2$ , here approximately 0.0071 wavelengths of the RF energy propagating therethrough and a length  $\phi$ , here approximately 0.6843 wavelengths of the RF energy propagating therethrough. The first end of the strip conductor 30 is connected along the edge 26 a distance  $D_1$ , here approximately 0.0188 wavelengths of the RF energy propagating therethrough, from a corner of the patch 12. The latter controls the impedance of the connection point as described hereinbefore and is se-

lected to match the impedance of the strip conductor 30.

The patch 14 and the patch 16 are disposed fore of the patch 12 a distance  $S_2$ , here approximately 0.3231 wavelengths of the RF energy propagating therethrough, as shown. The patch 14 and the patch 16 are disposed with a center to center spacing  $S_1$ , here approximately 0.8231 wavelengths of the RF energy propagating therethrough, as shown. The second end of the strip conductor 30 is connected to the patch 14 along an edge 32 of the patch 14. The edge 32 includes a notch 34 provided in the patch 14, the notch 34 having a depth  $D_3$ , here approximately 0.0305 wavelengths of the RF energy propagating therethrough, and a width  $D_4$ , here approximately 0.0611 wavelengths of the RF energy propagating therethrough. As described hereinabove, the patch 14 has a constant impedance along the width  $W$  of the patch 14. By connecting the end of the strip conductor 30 at the end of the depth of the notch 34, the impedance of the microstrip feed of the patch 14 is matched to the impedance of the strip conductor 30.

It should be appreciated that the patch 16 is connected to the patch 12 by strip conductor 30' along edge 26' and disposed having similar dimensions corresponding with patch 14 and strip conductor 30. Suffice it to say that patch 16 and strip conductor 30' are disposed as a mirror image to patch 14 and strip conductor 30. With the above described arrangement, patch 14 and patch 16 provide an image patch radiator element in front of the patch 12 for providing a desired end fire excitation. In a transmit mode, an RF signal is fed to the coaxial line 20 and coupled to the patch 12 wherein, acting as a resonant cavity, a portion of the RF signal is radiated from the patch 12. Another portion of the RF signal is coupled to the patch 14 by the strip conductor 30 wherein that portion of the RF signal is radiated from the patch 14. Still another portion of the RF signal is coupled to the patch 16 by the strip conductor 30' wherein that portion of the RF signal is radiated from the patch 16. By positioning the connection of the strip conductors 30, 30' as shown, nearly half of the RF signal is coupled from the patch 12 and split between the patch 14 and the patch 16. Alternatively, by changing the position of the connection of the strip conductors 30, 30', the impedance is changed which can be used to change the amount of RF energy fed to respective patches. It was observed that if the strip conductors 30, 30' are connected directly to respective patches and the length  $\phi$  is minimized, then the beam of RF energy is directed in an aft direction. To provide the proper directivity, the length  $\phi$  of strip conductors 30, 30' is appropriate to provide a  $-90$  degrees phase lag on the forward patches 14, 16 relative to patch 12. The latter provides an image element in front of the patch 12 with an RF signal having equal amplitude and a  $-90$  degree phase lag than that provided by the patch 12 which provides the desired end fire excitation. With the above described arrangement, the effects of mutual coupling caused by two patches in close proximity to each other are decreased as when a patch is located directly in front of the patch 12.

Referring now to FIG. 3, patch radiator antenna 10 is disposed on a missile cone and is protected by dielectric radome 42. Referring now to FIG. 4, a cross section is shown of the antenna assembly with dielectric radome 42 as the outer surface, the patch radiator antenna disposed on the surface of dielectric substrate 22, and the

conductive sheet 24 forming the ground plane of the antenna assembly.

Referring now to FIGS. 5A, 5B and 5C, a measured pattern for the patch radiator antenna 10 is shown at the center frequency of the antenna in FIG. 5A and a measured pattern for the patch radiator antenna 10' is shown at the center frequency of the antenna in FIG. 5B. It should be appreciated the patterns as shown in FIGS. 5A, 5B and 5C are about the axis of the missile 100 (FIG. 1) along the elevation (EL) axis and the azimuth (AZ) axis as indicated. As shown, the patch radiator antenna 10 and the patch radiator antenna 10' provide a one way gain in a near end fire direction of 6 dBi. As shown in FIG. 5C, the combined patterns have a resultant two way on axis gain of greater than 9 dBi with broad symmetric coverage over a 45 degree cone angle. The VSWR is less than 1.7:1 over the desired bandwidth, here 200 MHz.

Variations to the patch radiator antenna 10 were investigated by differing parameter values than that as described above. Table I shows the varying parameter values and the difference from the nominal design. All other parameters remained the same as described above.

TABLE I

Ckt	$\phi$ , phase length	L, patch length	D <sub>1</sub> , feed location	S <sub>1</sub> , patch separation	Difference
1	1.455	0.620	0.040	1.750	Nominal Design
2	1.375	0.615	0.040	1.750	less phase lag in forward patches
3	1.535	0.620	0.040	1.750	more phase lag in forward patches
4	1.455	0.605	0.040	1.750	shorter resonant patch
5	1.455	0.635	0.040	1.750	longer resonant patch
6	1.455	0.620	0.040	1.750	lower amplitude to forward patches
7	1.455	0.620	0.040	1.750	higher amplitude to forward patches
8	1.455	0.620	0.040	1.500	shorter forward patch separation
9	1.535	0.620	0.040	1.750	higher amplitude & more phase lag to forward patches
10	1.535	0.620	0.040	1.500	shorter patch separation & more phase lag to forward patches

It was observed that only minor variation in the performance was obtained for the various iterations. However, antenna configuration (Ck) No. 2 demonstrated a larger tuning margin about the center frequency and thus may be desirable for applications requiring larger bandwidths. It was also observed that tuning frequency was primarily a function of patch radiator length and that cross-coupling isolation in all iterations is greater than 25 db between opposite array pairs.

Referring now to FIGS. 3, 3A and 4, the patch radiator antenna 10 is shown disposed on the truncated cone 104. The truncated cone 104 is shaped with an angle here of approximately 15 degrees and having a center coincident with the missile axis. The patch radiator antenna 10 is disposed between the dielectric substrate 22 and a dielectric substrate 42. The dielectric substrates 22, 42 is constructed from a Quartz/Cyanate Ester resin composite, provided by Omohundro Company of Costa Mesa, Calif. 92627. The patch radiator antennas 10, 10' are electro deposited using  $\frac{1}{2}$  oz. copper on the Quartz/Cyanate Ester resin composite. Alternatively, to facilitate construction of the patch radiator antenna 10 and the patch radiator antenna 10', the patch radiator antennas 10 and 10' can be constructed on a common membrane 18 as shown in FIG. 3A. The membrane 18 can then be wrapped around the dielectric substrate 22 which in turn will properly disposed the patch radiator antenna 10 and 10' about the truncated ring 104. The dielectric substrate 22 is approximately 0.125 inches thick and a sheet 24 of conductive material is disposed

upon an inner surface of the dielectric substrate 22 to provide a ground plane. The dielectric substrate 22 is provided as a thick substrate to provide the requisite bandwidth for the patch radiator antenna 10. The dielectric substrate 42 is disposed over the patch radiator antenna 10 and the patch radiator antenna 10' to protect the latter from the environment.

Having described this invention, it will now be apparent to one of skill in the art that the number and disposition of the patch radiator elements may be changed without affecting this invention. Furthermore, active phase shifters could be included between the probe fed patch radiator and the patch radiators fed by the probe fed patch radiator to actively control the phase of the signal to change the directivity of the antenna. It is felt, therefore, that this invention should not be restricted to its disclose embodiment, but rather should be limited only by the spirit and scope of the appended claims.

What is claimed is:

1. A patch radiator antenna comprising:
  - a sheet of conductive material;
  - a dielectric substrate having a first and second surface, the sheet of conductive material disposed upon the first surface of the dielectric substrate;

a plurality of patch radiator elements disposed upon the second surface of the dielectric substrate, each one of the plurality of patch radiator elements having sides with a width and a length, said plurality of patch radiator elements comprising:

- a first patch radiator element comprising a feed probe to couple said first patch radiator element to an RF signal source;
- at least one second patch radiator element comprising a microstrip feed along the width of the second patch radiator element, the at least one second patch radiator element disposed fore of the first patch radiator element which is disposed aft of the at least one second patch radiator element; and
- a third different patch radiator element comprising a microstrip feed along the width of the third different patch radiator element, the third different patch radiator element disposed fore of the first patch radiator element which is disposed aft of the third different patch radiator, the patch radiator antenna further comprising a first strip conductor having a first end and a second end, the first end connected to the microstrip feed of the third different patch radiator element and the second end connected along the length of the first patch radiator element; and
- a second strip conductor having a first end and a second end, the first end connected to the micro-

strip feed and the second end connected along the length of the first patch radiator element.

2. The patch radiator antenna as recited in claim 1 wherein the width of each one of the patch radiator elements is approximately 0.3174 wavelengths of a signal propagating therethrough and the length of each one of the patch radiator elements is approximately 0.2916 wavelengths of the signal propagating therethrough.

3. The patch radiator antenna as recited in claim 1 wherein the second patch radiator element having a center is disposed adjacent the third different patch radiator element having a center with a center to center spacing of approximately 0.8213 wavelengths of a signal propagating therethrough.

4. The patch radiator antenna as recited in claim 3 wherein the first patch radiator element having a center is disposed with the center of the first patch radiator element spaced approximately 0.3231 wavelengths of a signal propagating therethrough from a point centered between the centers of the second patch radiator element and the third patch radiator element.

5. The patch radiator antenna as recited in claim 1 wherein the at least one second patch radiator element further comprises a notch having a depth with an end and the microstrip feed is disposed at the end of the depth of the notch.

6. The patch radiator antenna as recited in claim 5 wherein the depth of the notch is approximately 0.0305 wavelengths of a signal propagating therethrough.

7. The patch radiator antenna as recited in claim 1 wherein the second end of the strip conductor is connected to the first patch radiator element having a corner at a distance approximately 0.0188 wavelengths of a signal propagating therethrough along the length from the corner.

8. The patch radiator antenna as recited in claim 1 further comprising a second different dielectric substrate having a surface disposed adjacent the plurality of patch radiator elements to protect the plurality of patch radiator elements from the environment.

9. A patch radiator antenna comprising:

a first patch radiator having a pair of length edges; and

means for providing an image patch radiator element fore of the first patch radiator for providing a desired end fire excitation, said providing means comprising:

a second patch radiator having a microstrip feed, the second patch radiator disposed fore of the first patch radiator; and

a third patch radiator having a microstrip feed, the third patch radiator disposed fore of the first patch radiator; and

means for coupling a portion of RF energy propagating therethrough between the first patch radiator and the second patch radiator and between the first patch radiator and the third patch radiator, said coupling means comprising a first strip conductor having a first end and a second end, the first end connected to the first patch radiator along one of the length edges and the second end connected to the microstrip feed of the second patch radiator and a second strip conductor having a first end and

a second end, the first end connected to the first patch radiator along a different one of the length edges and the second end connected to the microstrip feed of the third patch radiator.

10. The patch radiator antenna as recited in claim 9 further comprising:

a first and second dielectric substrate, each dielectric substrate having a first and second surface, the first patch radiator disposed between the second surface of the first dielectric substrate and the first surface of the second dielectric substrate; and

a sheet of conductive material disposed on the first surface of the first dielectric substrate.

11. The patch radiator antenna as recited in claim 9 wherein the patch radiators, each having a width and a length, are disposed with the width of each one of the patch radiators is approximately 0.3174 wavelengths of a signal propagating therethrough and the length of each one of the patch radiators is approximately 0.2916 wavelengths of the signal propagating therethrough.

12. The patch radiator antenna as recited in claim 9 wherein the second and the third patch radiator further comprises a notch having a depth with an end and the microstrip feed is disposed at the end of the depth of the notch.

13. The patch radiator antenna as recited in claim 12 wherein the depth of the notch is approximately 0.0305 wavelengths of a signal propagating therethrough.

14. A method of providing a patch radiator antenna comprising the steps of:

providing a dielectric substrate having a first and second surface with a conductive material disposed on the first surface;

disposing a plurality of patch radiator elements on the second surface of the dielectric substrate, each one of the plurality of patch radiator elements having a width and a length; and

connecting a first patch radiator element to a second and a third different patch radiator element with a respective first and second strip conductor having a first end and a second end, said second and third different patch radiator element disposed fore of the first patch radiator element, the first end of the first strip conductor connected along the width of the second patch radiator element and the second end of the first strip conductor connected along the length of the first patch radiator and the first end of the second strip conductor connected along the width of the third patch radiator element and the second end of the second strip conductor connected along an opposing length of the first patch radiator.

15. The method as recited in claim 14 further comprising the steps of:

providing a coaxial probe feed to the first patch radiator element to provide a feed for the patch radiator antenna.

16. The method as recited in claim 14 further comprising the steps of:

providing a second dielectric substrate having a first and second surface with the plurality of patch radiator elements disposed adjacent the first surface, said second dielectric substrate surrounding said first dielectric substrate.

\* \* \* \* \*

# APPENDIX F



US006134420A

# United States Patent [19]

[11] Patent Number: 6,134,420

Flowerdew et al.

[45] Date of Patent: Oct. 17, 2000

[54] VECTOR MEASURING AERIAL ARRAYS FOR MAGNETIC INDUCTION COMMUNICATION SYSTEMS

5,437,057	7/1995	Richley et al.	455/41
5,568,005	10/1996	Davidson .	
5,568,616	10/1996	Strohallen et al.	375/259
5,612,652	3/1997	Crosby	333/24
5,694,139	12/1997	Saito et al.	343/866
5,734,353	3/1998	Van Voorhies .	
5,771,438	6/1998	Palermo et al.	455/41
5,966,641	10/1999	Flowerdew	455/41

[75] Inventors: Peter M. Flowerdew; David Huddart, both of Bristol, United Kingdom

[73] Assignee: Plantronics, Inc., Santa Cruz, Calif.

[21] Appl. No.: 09/010,807

### FOREIGN PATENT DOCUMENTS

WO 92/00635	1/1992	European Pat. Off.	455/41
WO 96/37052	11/1996	European Pat. Off.	H04B 5/02

[22] Filed: Jan. 22, 1998

(List continued on next page.)

### Related U.S. Application Data

[63] Continuation-in-part of application No. 08/742,337, Nov. 1, 1996, Pat. No. 5,966,641.

[51] Int. Cl.<sup>7</sup> ..... H04B 5/02

[52] U.S. Cl. .... 455/41; 455/129; 455/269; 455/562; 343/867

[58] Field of Search ..... 343/867, 788; 455/41, 129, 269, 562, 274, 517

Primary Examiner—Nguyen Vo  
Attorney, Agent, or Firm—Fenwick & West LLP

### [57] ABSTRACT

A wireless communication system automatically aligns a magnetic induction field to establish a two-way communication link between a stationary base unit located, for example, at a user's work station, and a remote unit worn by the user, for example, as a headset or body pack. At any point in time, the base unit and the remote unit have an arbitrary relative orientation to each other. The base unit senses this orientation, then aligns the magnetic induction field to maintain the communication link with the remote unit. In one embodiment, the base unit preferably includes an aerial array having a number of mutually orthogonal windings. Each winding produces a signal when a magnetic induction field generated by the remote unit passes through the base unit. A selector module selects the longitudinal axis of the winding with the strongest signal as an approximation of a direction vector defining the orientation of the magnetic induction field relative to the base unit. In another embodiment, the base unit preferably includes an aerial array comprising three orthogonal windings disposed about a spherical core. A selector module selects one or more windings for transmitting a magnetic field that rotates in a plane orthogonal, i.e., "crossed field," to the direction vector defining the orientation of the received field relative to the base unit.

### [56] References Cited

#### U.S. PATENT DOCUMENTS

1,554,231	9/1925	Press .	
3,569,969	3/1971	Lemon, Jr.	343/225
3,591,710	7/1971	Uetake et al. .	
3,601,550	8/1971	Spracklen	179/82
3,660,760	5/1972	Schaad et al.	325/28
3,711,651	1/1973	Connell	179/15 BT
3,750,180	7/1973	Fujimoto et al. .	
3,766,476	10/1973	Silitch	325/26
3,809,825	5/1974	Schaad et al.	179/82
4,250,507	2/1981	Wingard	343/742
4,747,158	5/1988	Goldberg et al.	455/11
4,751,515	6/1988	Corum .	
4,908,869	3/1990	Lederman	381/79
4,922,261	5/1990	O'Farrell	343/742
4,941,201	7/1990	Davis	455/41
5,027,709	7/1991	Slagle	102/427
5,032,947	7/1991	Li et al. .	
5,258,766	11/1993	Murdoch	343/742
5,321,412	6/1994	Kopp et al.	343/742
5,420,579	5/1995	Urbas et al. .	
5,426,409	6/1995	Johnson	336/178

16 Claims, 17 Drawing Sheets

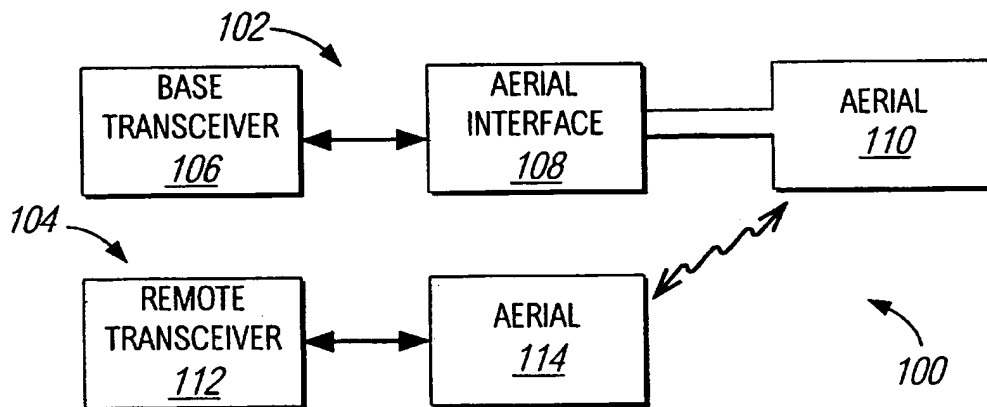



---

FOREIGN PATENT DOCUMENTS			
	225901	2/1943	Switzerland ..... 343/867
	1164281	9/1969	United Kingdom ..... H04B 5/00
WO 97/08914	3/1997	European Pat. Off. ....	H04Q 9/00
27 08 464	9/1977	Germany .....	H04B 1/18
06253375	9/1993	Japan .....	H04Q 9/00
06253375	9/1994	Japan .....	H04Q 9/00
	21 232 14	1/1984	United Kingdom ..... 343/867
	21 557 36	9/1985	United Kingdom ..... H04B 5/00
	21 97 160	5/1988	United Kingdom ..... H04B 5/02
	WO 96/37052	11/1996	WIPO ..... H04B 5/02

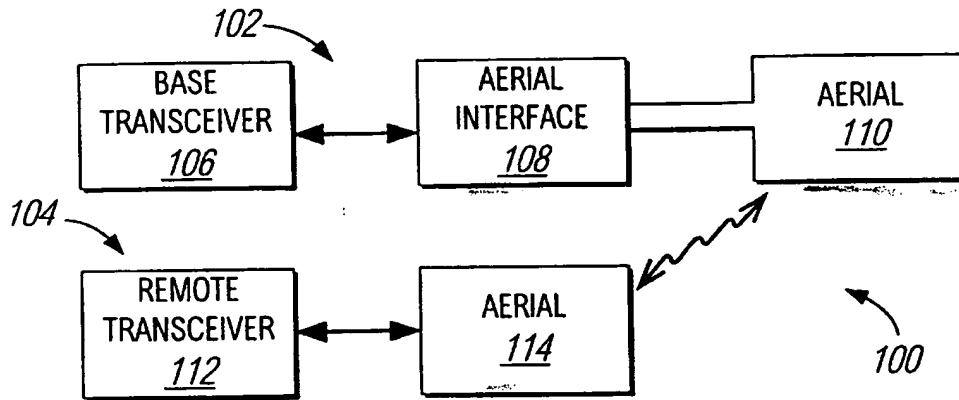

FIG. 1

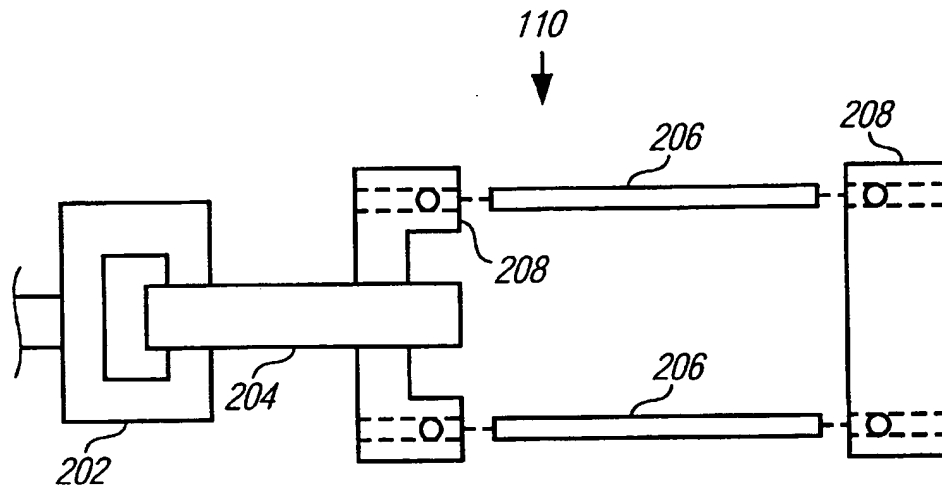

FIG. 2

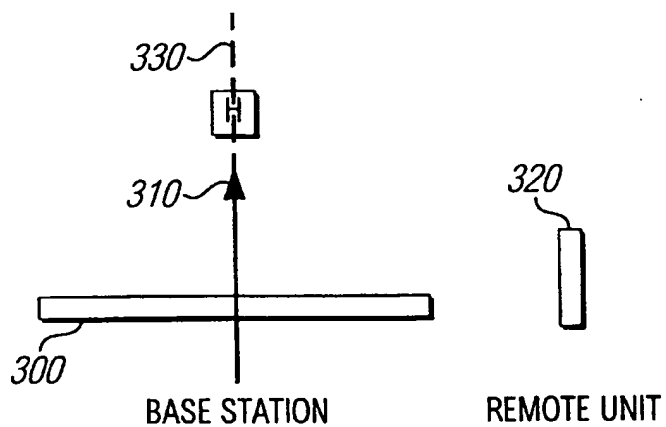

FIG. 3

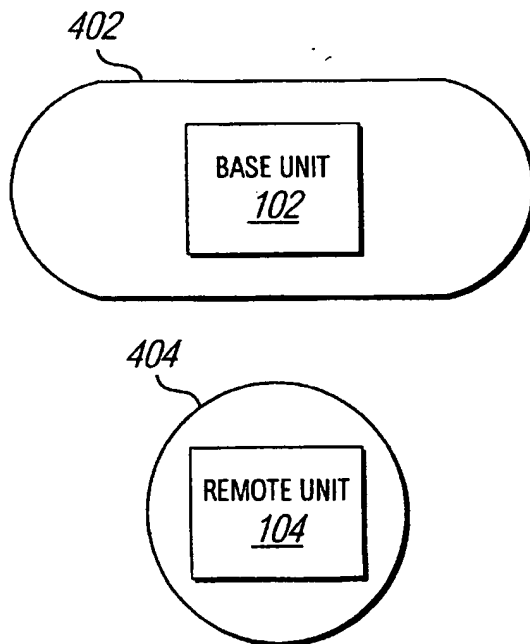

FIG. 4

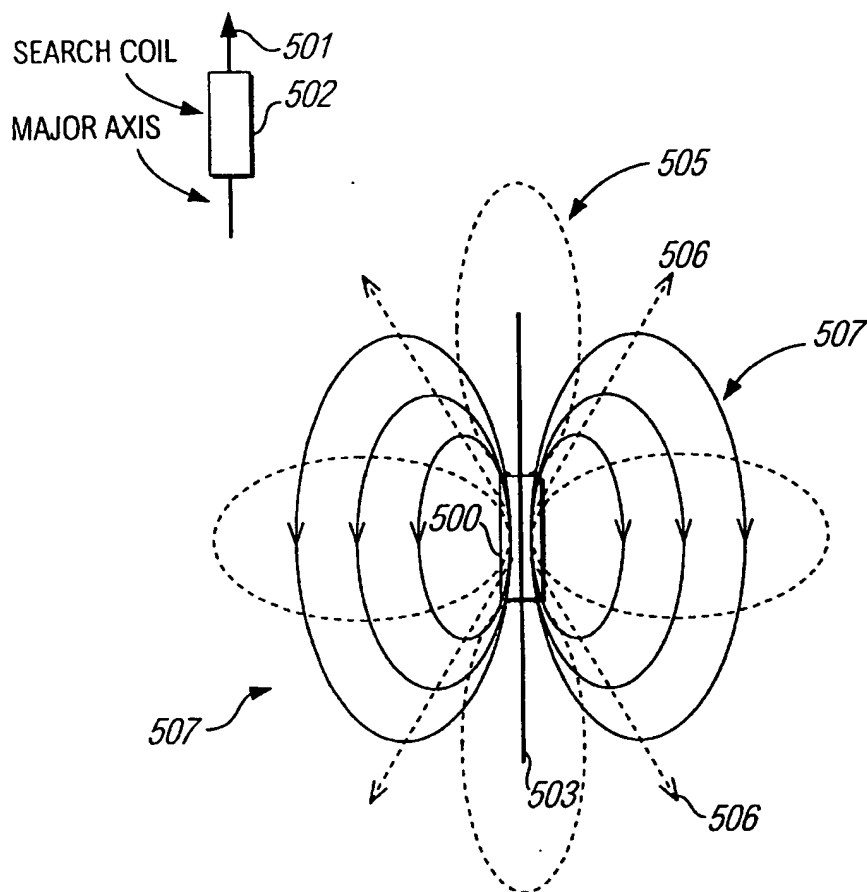

FIG. 5

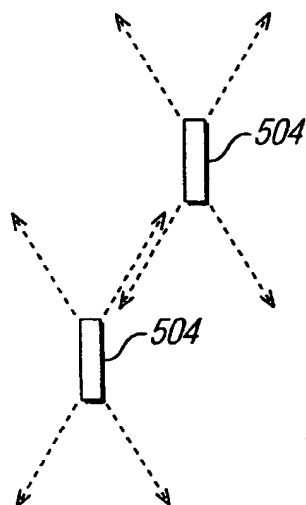

FIG. 6

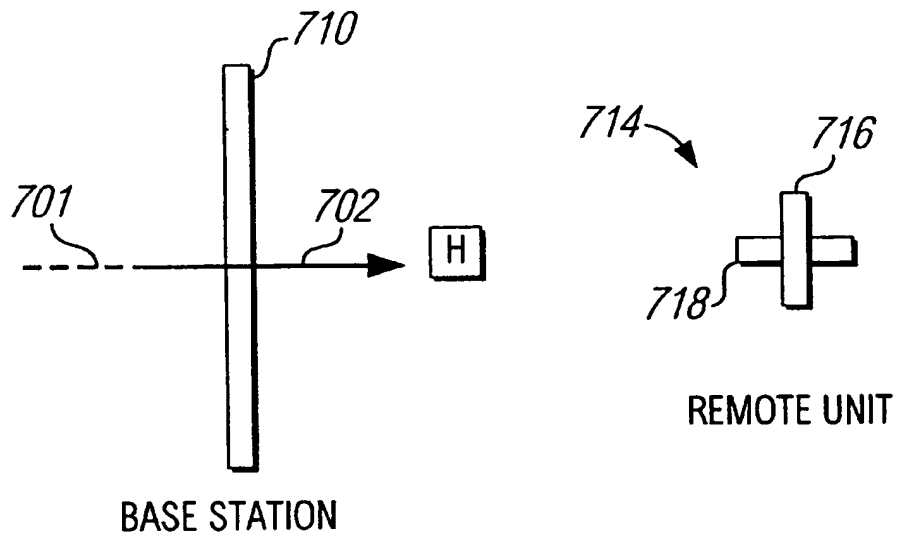

FIG. 7

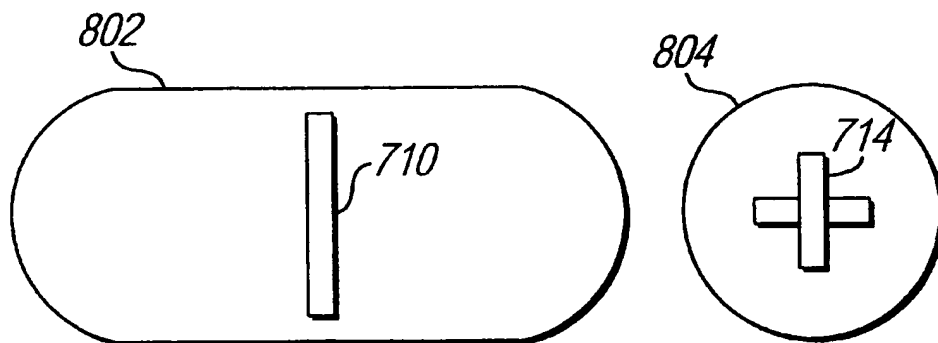

FIG. 8

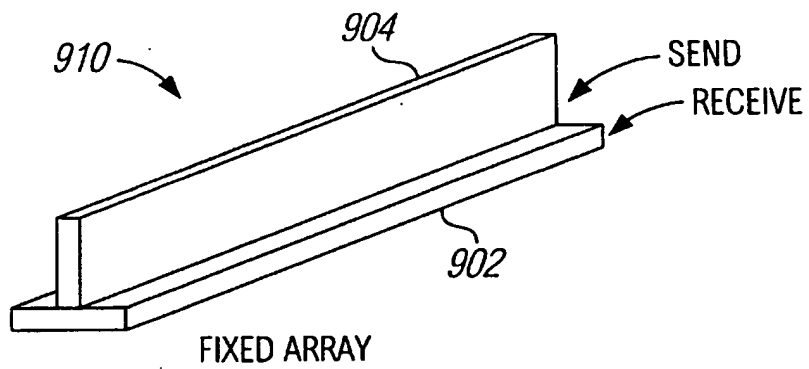

FIG. 9A

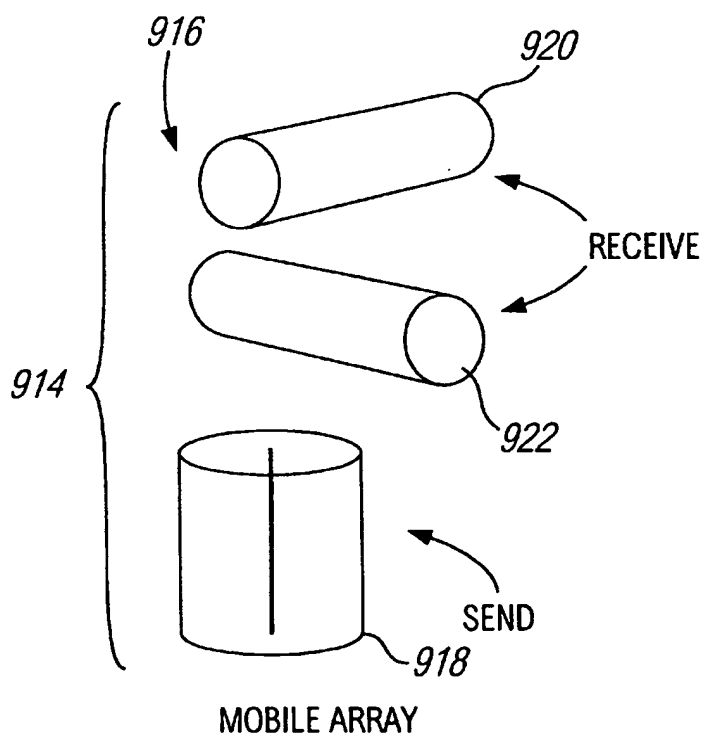

FIG. 9B

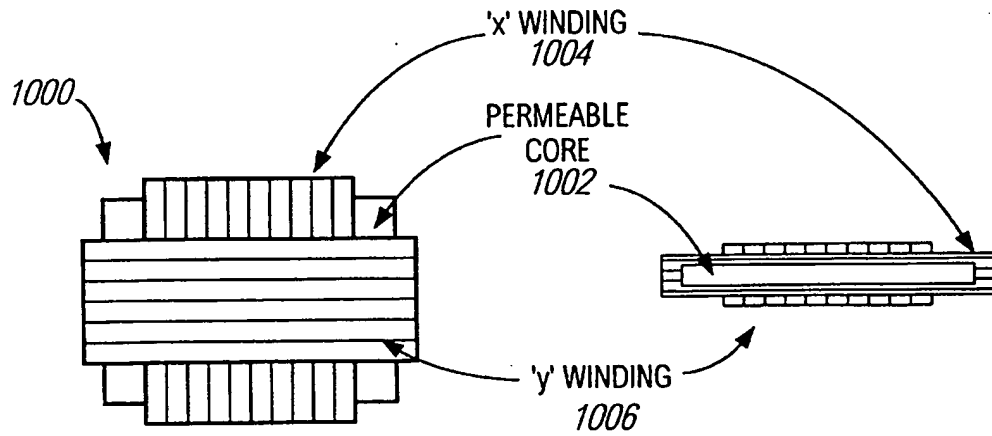

FIG. 10A

FIG. 10B

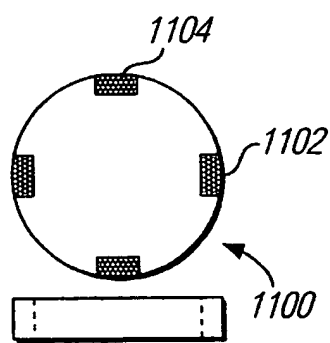

FIG. 11A

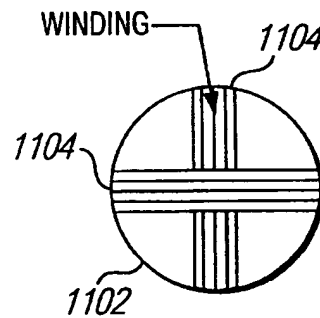

FIG. 11B

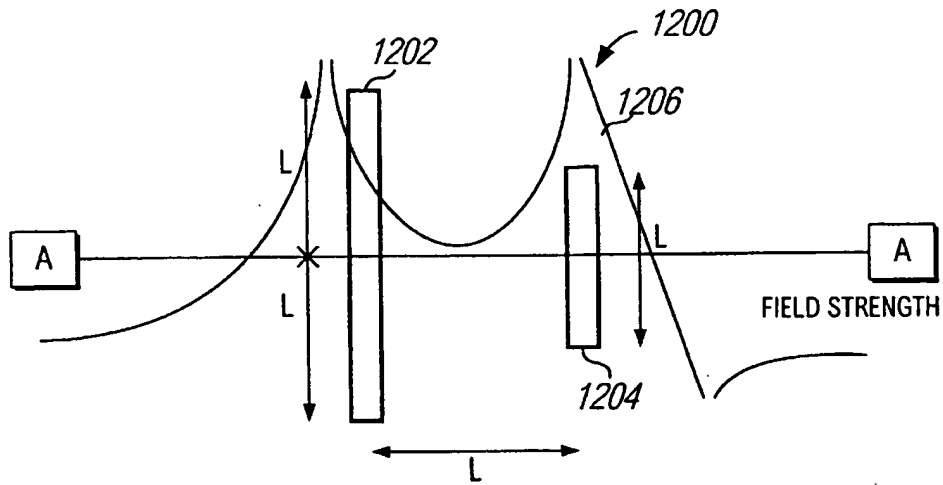
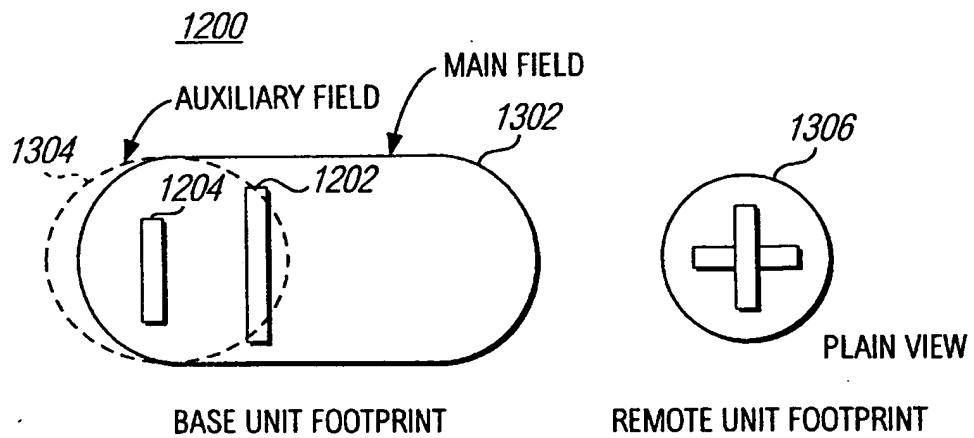

FIG. 12



NOTE:  
AUXILIARY FIELD  
IS ANTIPHASE TO  
MAIN FIELD

FIG. 13A



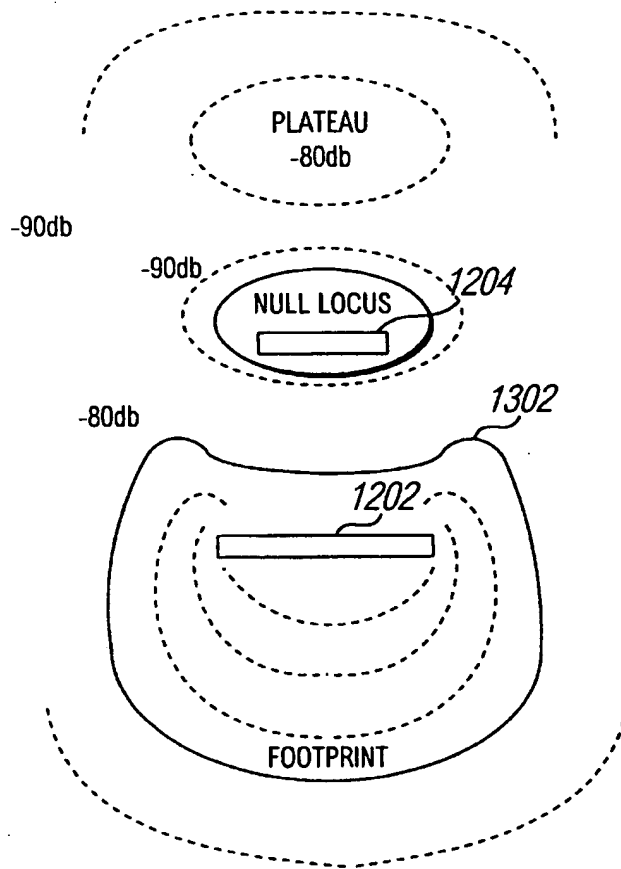

FIG. 13B

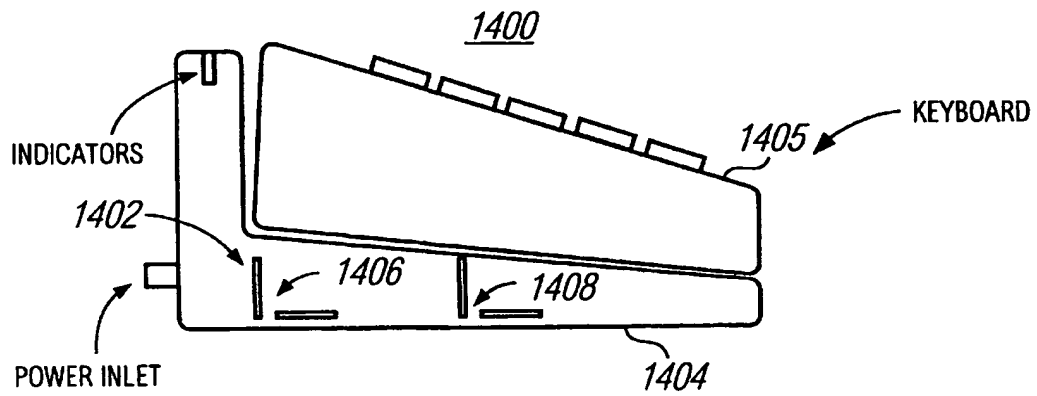
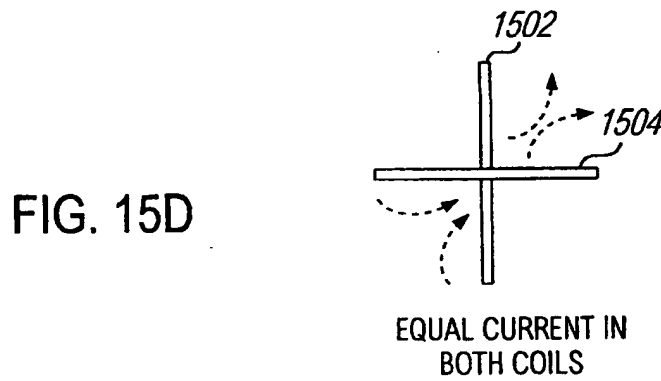
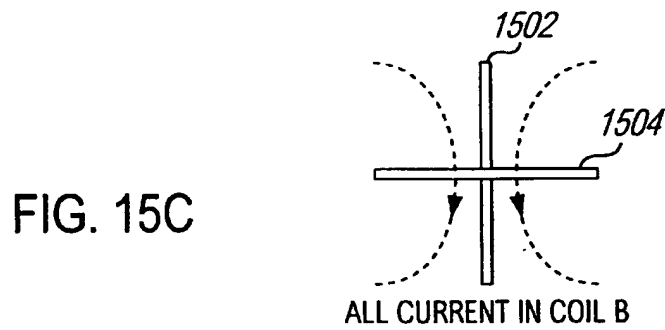
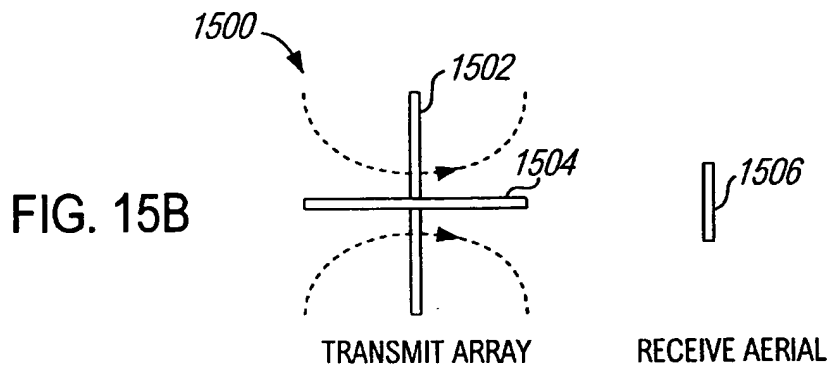
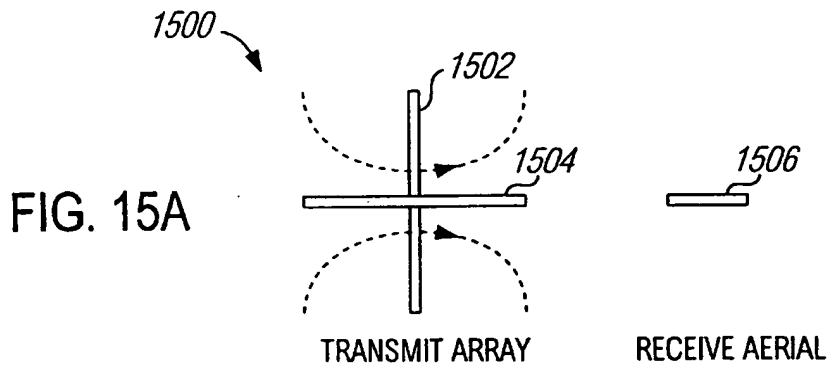

FIG. 14



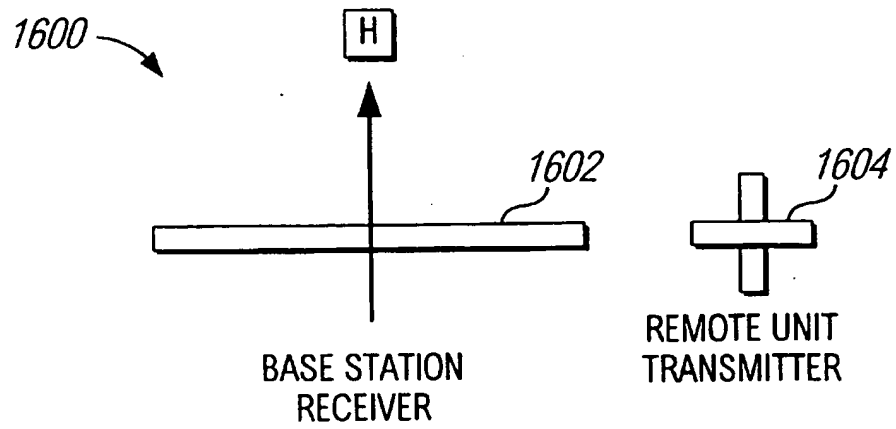

FIG. 16

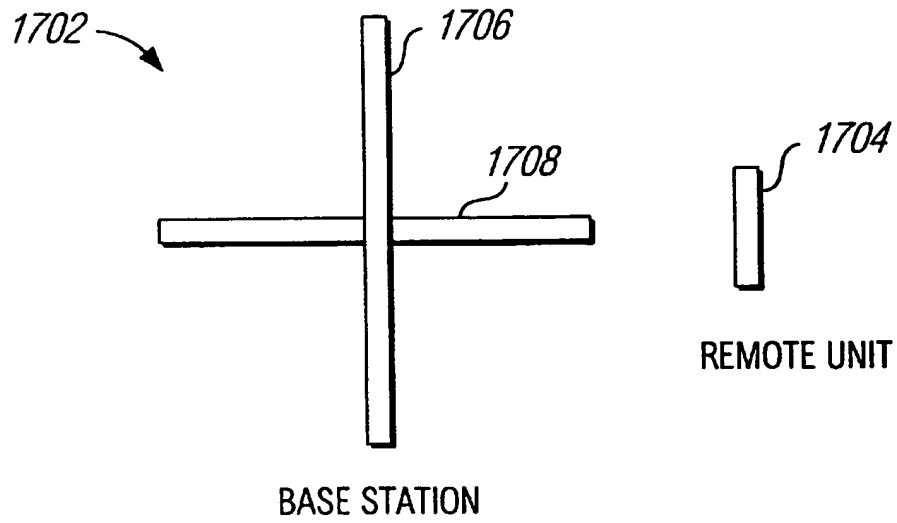

FIG. 17

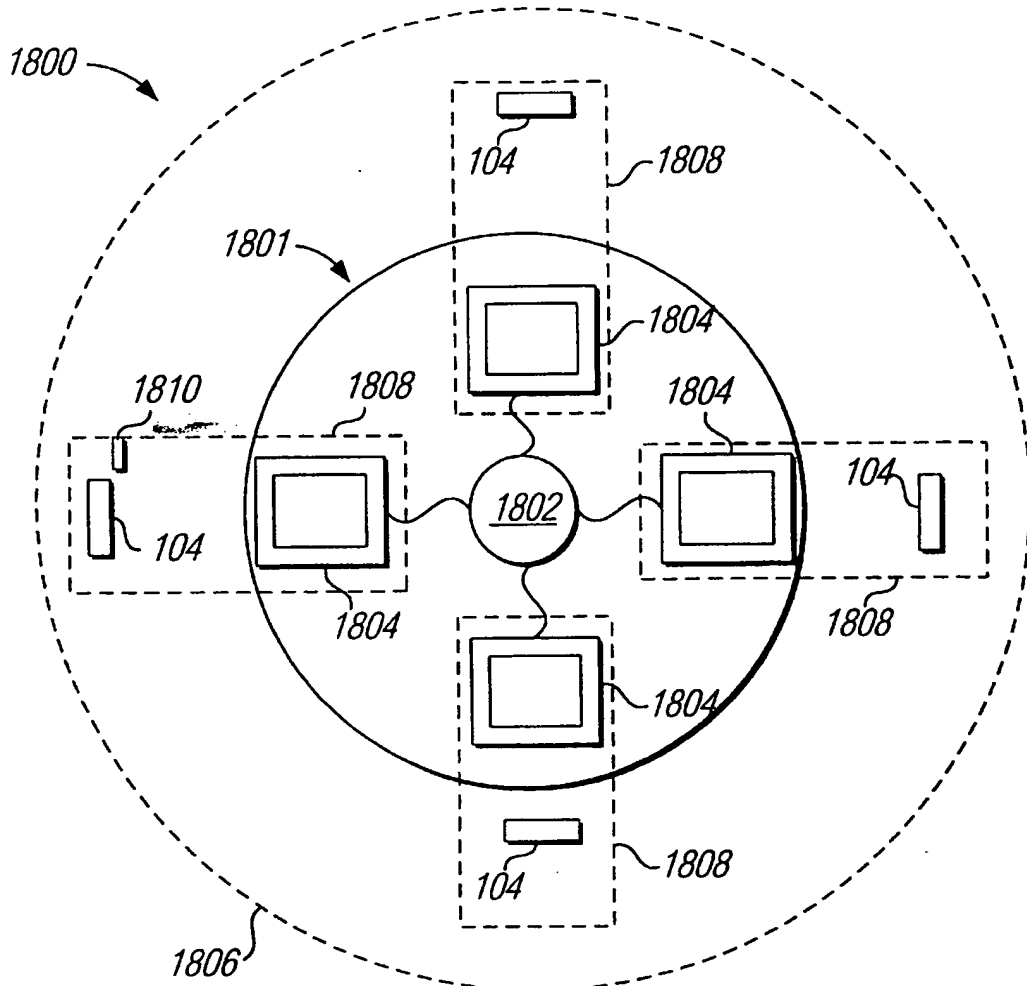

FIG. 18

FIG. 19A

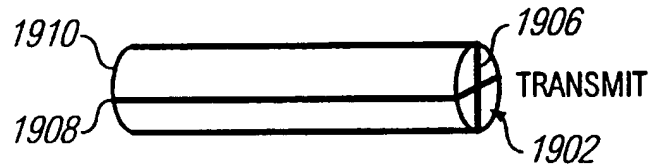
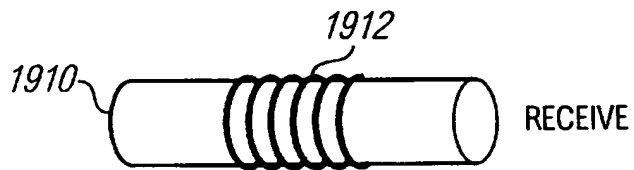

FIG. 19B



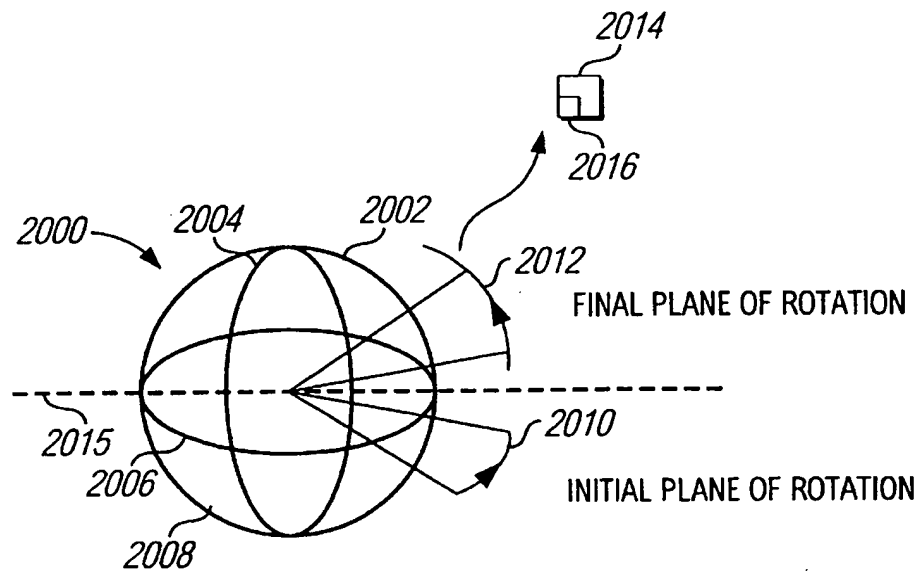

FIG. 20

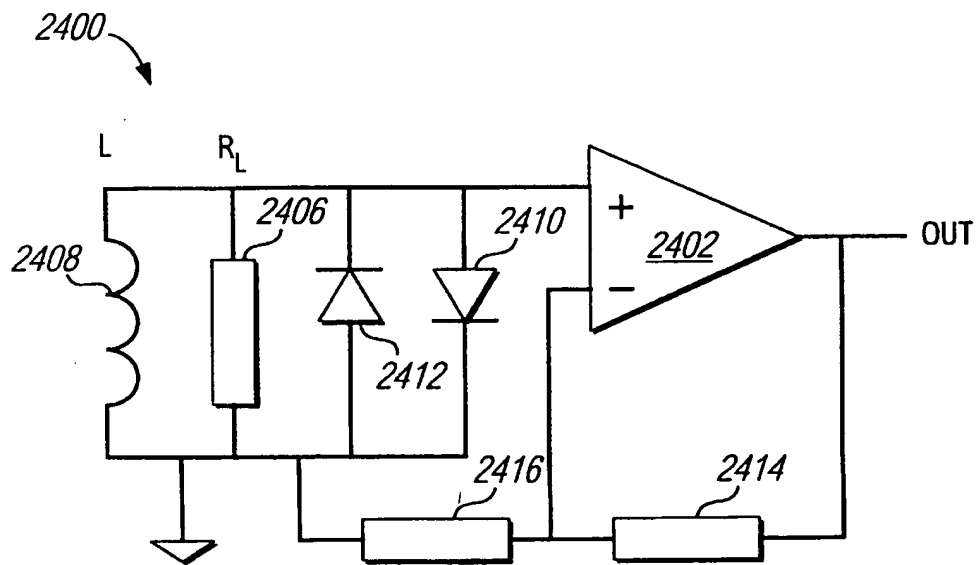

FIG. 24

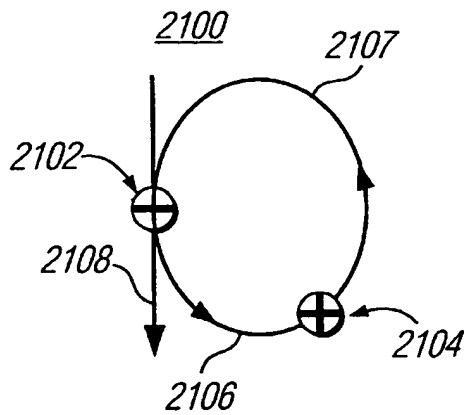

FIG. 21A

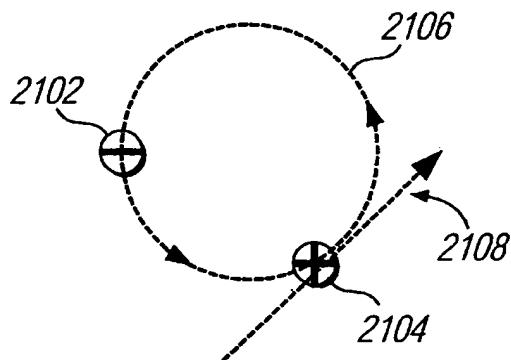

FIG. 21B

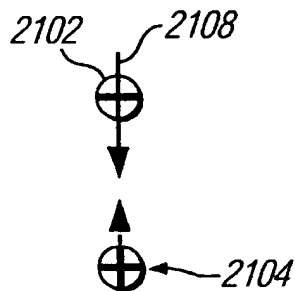

FIG. 21C

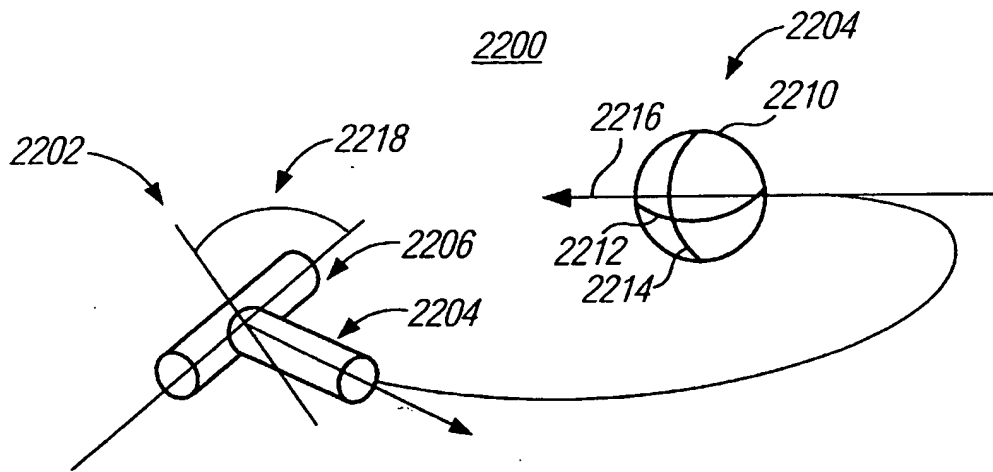

FIG. 22A

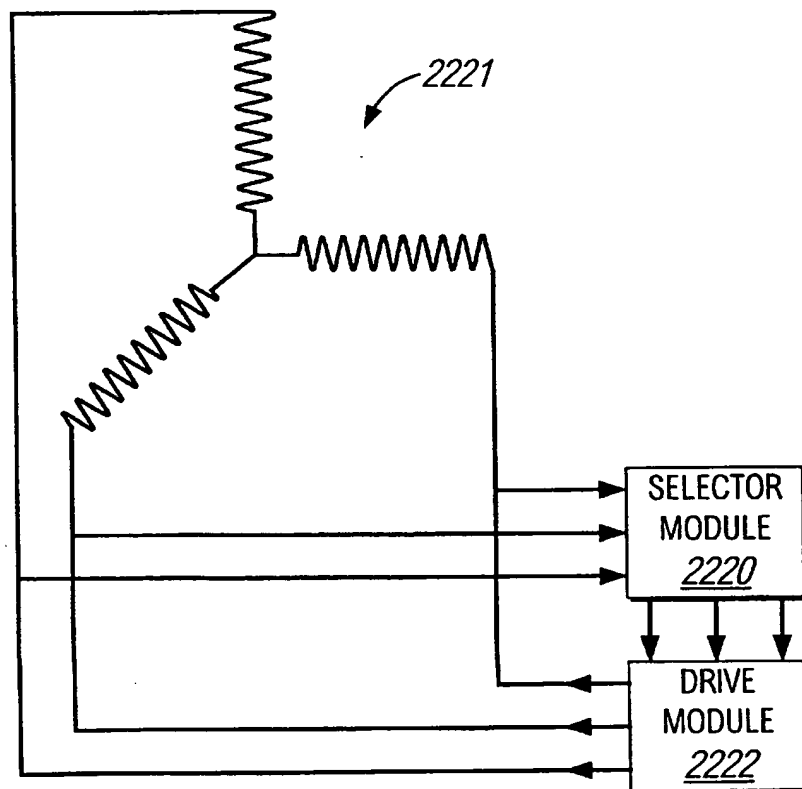

FIG. 22B

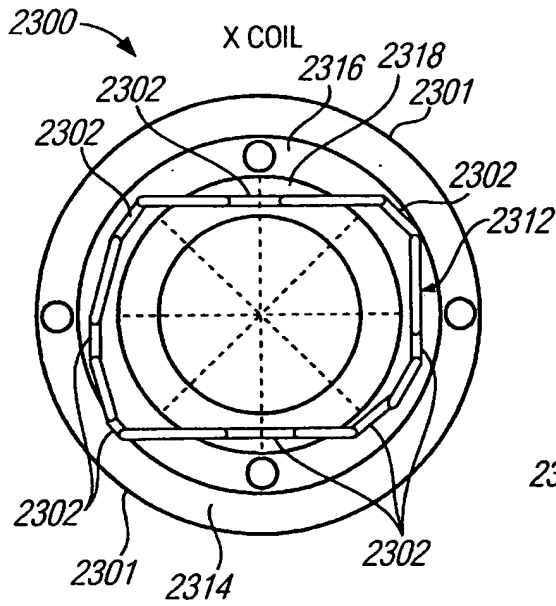

FIG. 23A

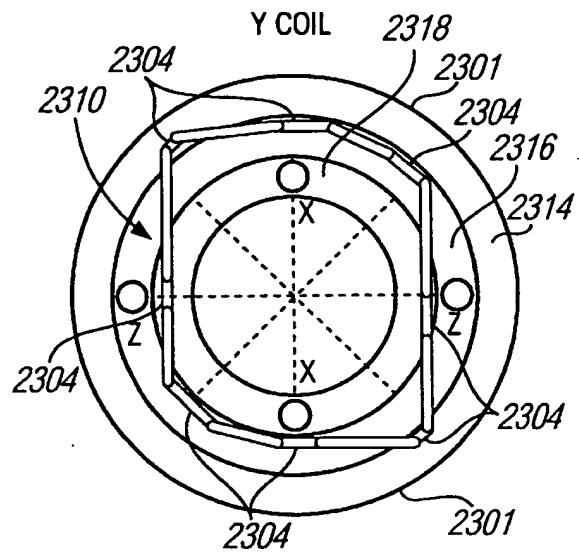

FIG. 23C

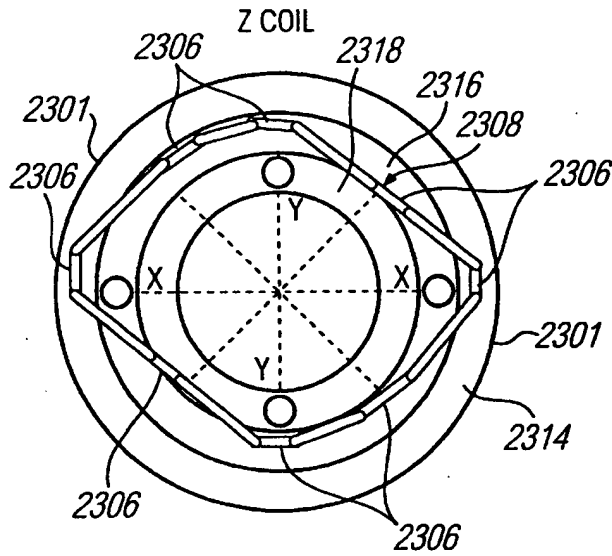

FIG. 23B



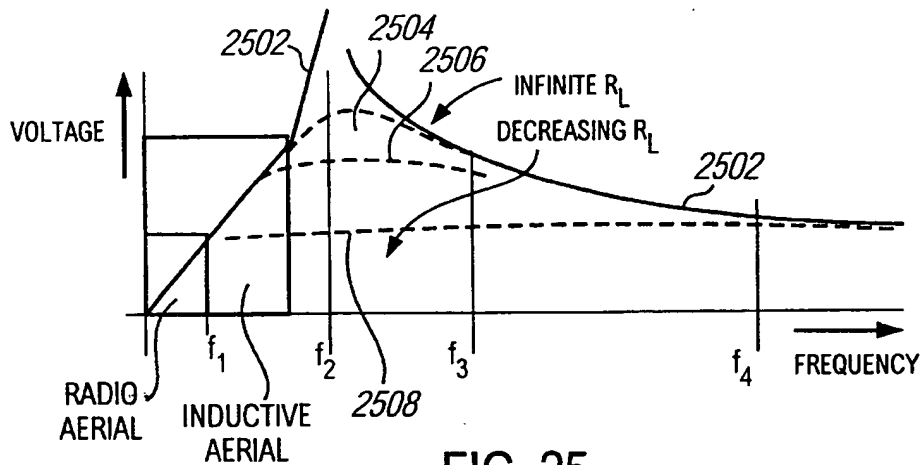

FIG. 25

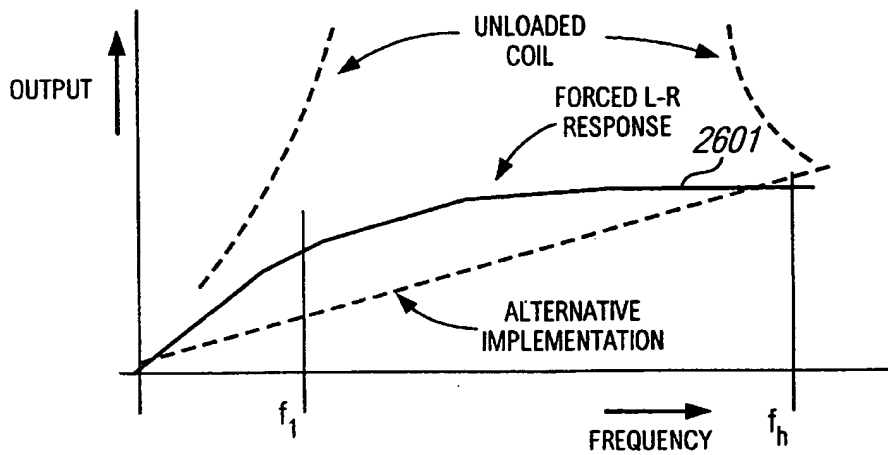

FIG. 26

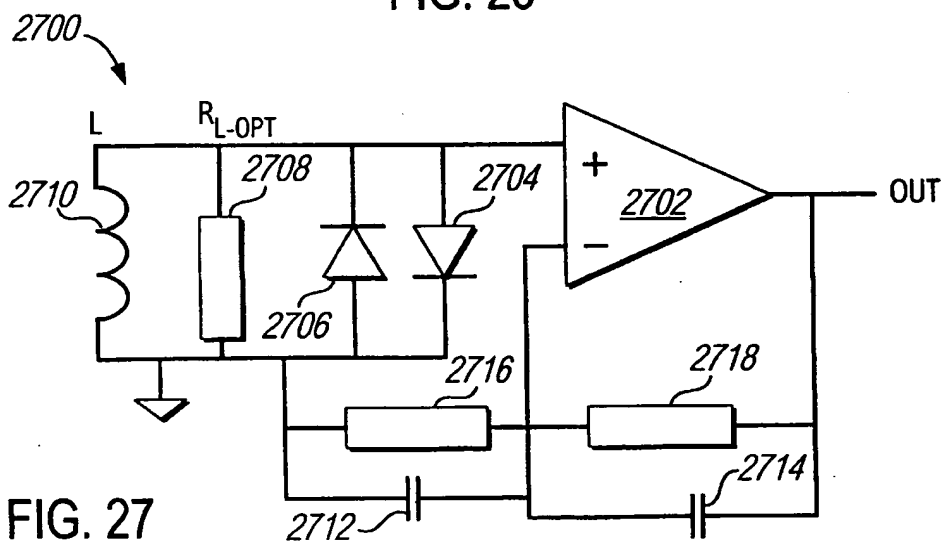

FIG. 27

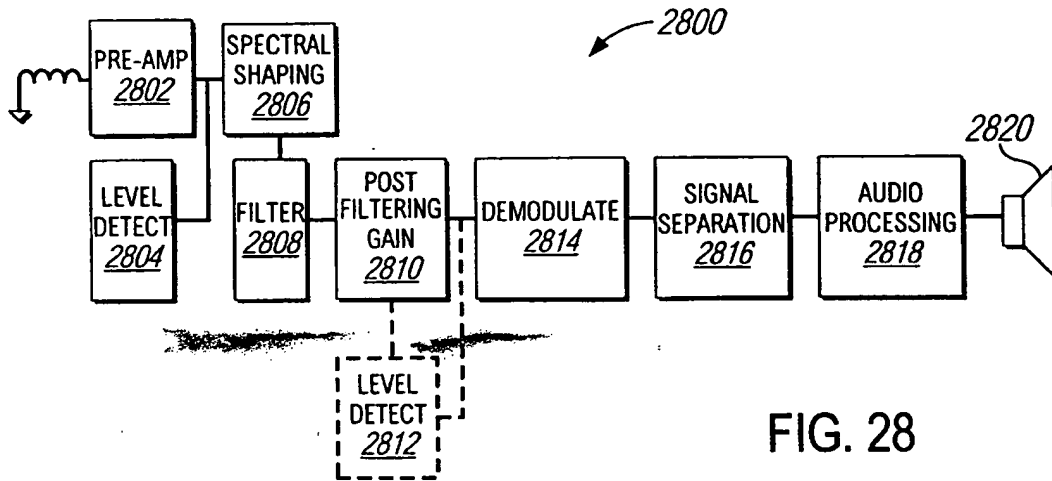

FIG. 28

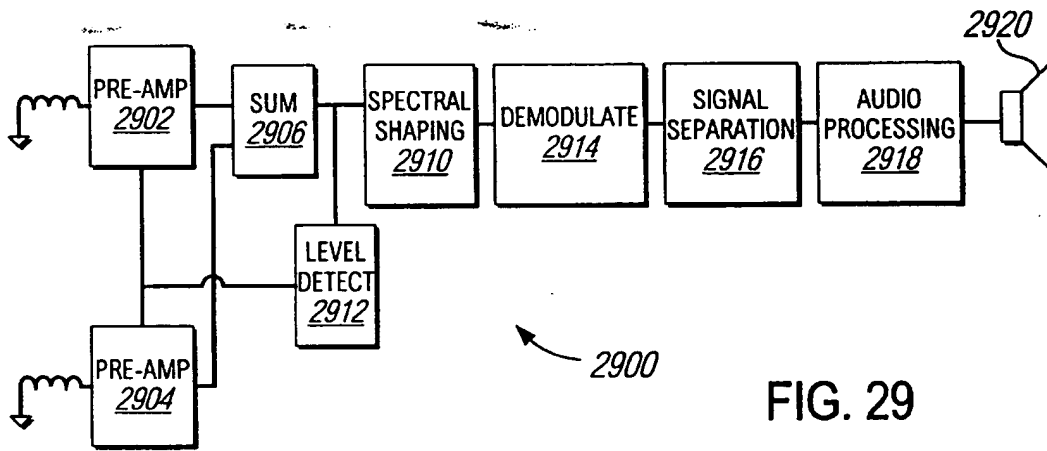

FIG. 29

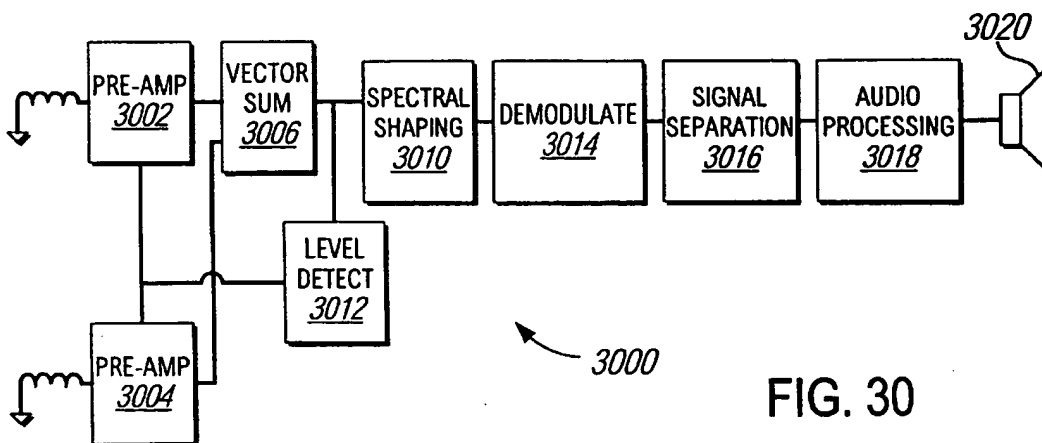

FIG. 30

**VECTOR MEASURING AERIAL ARRAYS  
FOR MAGNETIC INDUCTION  
COMMUNICATION SYSTEMS**

**CROSS-REFERENCE TO RELATED  
APPLICATIONS**

This application is a continuation-in-part of application Ser. No. 08/742,337, filed on Nov. 1, 1996, for "Aerial Arrays for Inductive Communication Systems." U.S. Pat. No. 5,966,641.

**FIELD OF THE INVENTION**

This invention relates to aerial arrays for wireless communication systems, and more particularly to aerial arrays that automatically align a magnetic induction field to establish a communication link.

**BACKGROUND OF THE INVENTION**

In local wireless communication systems, such as telephone systems, a base station communicates voice data between a telephone line and a remote unit, such as a headset, worn by a user. These conventional systems typically transmit data from the base station over a wide area adjacent to the base station. Moreover, these systems typically use ultrasound, radio frequency (RF), or infrared carrier signals to transmit data between transmitters and receivers in the base and remote units. These carrier signals are subject to "scattering" and may interfere with other nearby transmitters and receivers.

In addition, ultrasonic and infrared systems require a line-of-sight communication channel between transmitters and receivers which may limit their usefulness for certain short range applications. Likewise, the usefulness of RF systems for certain short range applications may be limited by a "1/r" signal decay rate, where "r" is the effective range of the transmitted RF signal.

Magnetic Induction (MI) communication systems have been used in commercial applications, such as audio loops in buildings, direct speech communication through security screens, and low-rate data links between underground equipment and surface equipment. The security screens typically include coils built into fixed desk mats on both sides of the screen. These systems have a short transmission range, thus making them more suitable for certain short range applications than their RF counterpart, but do not allow movement of one mat relative to the other.

One type of MI system provides a user with a telephone headset connected to a remote unit. The remote unit communicates with a stationary base unit at the user's desk. In such an environment, the user can move about within their workspace, resulting in an arbitrary orientation (i.e., height, distance, and angle) between the base unit and the remote unit that changes over time. It is desirable that such a system allow the user to move within a work area around the work station without a loss of, or a break in, the communication link due to such changes in orientation. It is also desirable that such a system be simple and inexpensive to implement.

Accordingly, there is a need for a simple and inexpensive wireless communication system that establishes and maintains a communication link between a base unit and a remote unit having a relative orientation to each other that changes over time.

**SUMMARY OF THE INVENTION**

The present invention is directed to a wireless communication system that automatically aligns a magnetic induction

field to establish a two-way communication link between a stationary base unit and a remote unit worn by the user, for example, as a headset or body pack. When the user moves within their work area, a first aerial in the base unit and a second aerial in the remote unit have an arbitrary relative orientation to each other. The base unit senses this orientation, then aligns the magnetic induction field to maintain an optimum coupling between the first aerial and the second aerial in the base unit and the remote unit, respectively.

The complexity of duplex filtering associated with maintaining the communication link is reduced by arranging the aerials in the base unit and the remote unit to have zero mutual inductance rather than build conventional duplex filters which can be bulky at the frequencies used for MI. While the remote unit preferably uses a simple aerial (e.g., single-axis aerial), the base unit uses a multi-axis aerial because it is responsible for maintaining the integrity of the communication link by automatically aligning the magnetic induction field for maintaining a two-way communication link with the remote unit.

In one embodiment of the present invention, a remote unit preferably includes a single-axis aerial that generates a first quasi-static magnetic induction field for communicating with a base unit. The base unit preferably includes a multi-axis aerial array having a number of mutually orthogonal windings wound around a single permeable core or, alternatively, a number of mutually orthogonal single-axis aerials, each having a single winding on a separate permeable core. Each winding produces a signal when a first magnetic induction field generated by the remote unit passes through the multi-axis aerial array in the base unit. The signal strength in each winding is a measure of a component of a direction vector along the longitudinal axis of that winding that defines the orientation of the first magnetic induction field relative to the multi-axis aerial array in the base unit.

More particularly, when the first magnetic induction field passes through the base unit, a voltage is induced in each winding. The voltage in each winding is a measure of the strength of the first component of the first magnetic induction field along the longitudinal axis of that winding. A transmission drive is then applied to each winding that is proportional to the voltage in that winding, thus aligning the second magnetic induction field with the first magnetic induction field. This alignment of the first and second magnetic induction fields establishes a two-way communication link with the remote unit, thus allowing communication signals to be transmitted back to the remote unit.

In another embodiment of the present invention, the longitudinal axis of the winding in the base unit receiving the strongest signal (i.e., having the greatest induced voltage) is taken as an approximation to the direction vector of the first magnetic induction field generated by the remote unit. Upon selection of that winding by a selector module, a transmission drive proportional to the received signal is applied to the same winding, or a winding co-axial to such winding, to generate the second field for establishing the communication link with the remote unit.

In another embodiment of the present invention, the base unit and the remote unit communicate using a "crossed field" system. The base unit preferably includes a multi-axis aerial array comprising three mutually orthogonal windings wound on a spherical, permeable core. In this embodiment, a transmission drive is applied to the windings for generating a second magnetic induction field that rotates

in a plane orthogonal to the direction vector defining the orientation of the first magnetic induction field relative to the multi-axis aerial array in the base unit. This "crossed field" induces in the remote unit a voltage in a winding disposed about a receive aerial (e.g., solenoid aerial) located proximate to and orthogonal with a transmit aerial in the remote unit, thus forming a communication link between the base unit and the remote unit.

Aerial arrays that are made in accordance with the present invention maintain a two-way MI communication link between a base unit and a remote unit having a relative orientation to each other that changes over time as the user moves in their work space. The windings in these aeri-  
als are arranged to have near zero mutual inductance, thus reducing the need for complex duplex filtering. These aerial arrays provide a simple and inexpensive implementation.

#### BRIEF DESCRIPTION OF THE DRAWINGS

FIG. 1 is a block diagram of one embodiment of a MI communication system in accordance with the subject matter of the invention.

FIG. 2 is a block diagram of one embodiment of an aerial interface of the communication system of FIG. 1 in accordance with the subject matter of the invention.

FIG. 3 is a side view of a vertical field configuration of aeri-  
als in accordance with the subject matter of the invention.

FIG. 4 is a top plan view illustrating the response areas for the base unit and the remote unit of FIG. 1.

FIG. 5 is a side view illustrating the magnetic flux lines and null lines of a solenoid aerial.

FIG. 6 is a side view illustrating the mutual nulling of a pair of solenoid aeri-  
als.

FIG. 7 is a side view of a horizontal field configuration of aeri-  
als in accordance with the present invention.

FIG. 8 is a top plan view illustrating the response area for the base unit and the remote unit of FIG. 7.

FIG. 9a is a partial perspective view of one embodiment of a fixed aerial array in accordance with the present invention.

FIG. 9b is an exploded view of one embodiment of a mobile aerial array in accordance with the present invention.

FIGS. 10a and 10b are top and side plan views, respectively, of one embodiment of an aerial array for a remote unit in accordance with the present invention.

FIGS. 11a-11b are transverse cross-sectional and top plan views, respectively, of an aerial array for a remote unit in accordance with the present invention.

FIG. 12 is a top plan view illustrating the field strength of one embodiment of an aerial array in accordance with the present invention.

FIG. 13a is a top plan view illustrating the response area for a remote unit and a base unit that includes the aerial array of FIG. 12.

FIG. 13b is a top plan view illustrating the response area of the aerial array of FIG. 12 where the aerial array is driven in antiphase.

FIG. 14 is a cross-sectional view of a keyboard including the aerial array of FIG. 12 in accordance with the present invention.

FIGS. 15a, 15b, 15c and 15d are side views of the steered rotating field lines of a crossed aerial array in accordance with the present invention.

FIG. 16 is a side view of one embodiment of a vertical rotating field communication link in accordance with the present invention.

FIG. 17 is a top plan view of one embodiment of a horizontal rotating field communication link in accordance with the present invention.

FIG. 18 is a top plan view of one embodiment of a communication cluster system in accordance with the present invention.

FIGS. 19a and 19b are views of one embodiment of a transmit aerial and a receive aerial, respectively, of a solenoid array in accordance with the present invention.

FIG. 20 is a diagram illustrating the geometry and tilting of a plane of rotation of one embodiment of a tri-axial transmitting antenna in accordance with the present invention.

FIGS. 21a and 21b are top plan views of one embodiment of a vector measuring system in accordance with the present invention.

FIG. 21c is a top plan view illustrating an optimum coupling between a first aerial in the base unit 102 and a second aerial in the remote unit 104.

FIG. 22a is a perspective drawing of one embodiment of a vector measuring system using rotational fields in accordance with the present invention.

FIG. 22b is an illustration of a selector module and a drive module in accordance with the present invention.

FIGS. 23a, 23b, and 23c are shown cross-sectional views of one embodiment of a tri-axial transmitting antenna array along orthogonal planes in accordance with the present invention.

FIG. 24 is a schematic diagram illustrating a conventional pre-amplifier for an inductive receiver.

FIG. 25 is a graph illustrating the frequency response of the conventional pre-amplifier of FIG. 24.

FIG. 26 is a graph illustrating the frequency response of the conventional pre-amplifier of FIG. 24 with varying load resistance.

FIG. 27 is a block diagram of one embodiment of a frequency shaping pre-amplifier in accordance with the present invention.

FIG. 28 is a block diagram of one embodiment of a receive circuit for a receive aerial in accordance with the present invention.

FIG. 29 is a block diagram of one embodiment of a receive circuit for a directional array in accordance with the present invention.

FIG. 30 is a block diagram of one embodiment of a receive circuit for a dual-axis aerial in accordance with the present invention.

#### DESCRIPTION OF THE PREFERRED EMBODIMENTS

Referring to FIG. 1, there is shown a block diagram of an inductive communication system 100. The communication system 100 includes a base unit 102 and a remote unit 104 that communicate over a short range through a magnetic induction link. The communication system 100 may be, for example, a telephone that includes a wireless communication link between the base unit 102 at a user workstation and the remote unit 104, which is part of an audio headset or body pack worn by an operator. A plurality of communication systems 100 may be used, for example, in an office environment.

The base unit 102 includes a base transceiver 106, an aerial interface 108, and a base aerial 110. The base aerial 110 generates a first magnetic induction field for commu-

nicating data from the base unit 102 to the remote unit 104 and receives a second magnetic induction field from the remote unit 104. The base unit 102, or only some elements of the base unit 102 (such as the base aerial 110), may be, for example, disposed on or in a desk surface, on a floor mat, in a bench mat, or inside a keyboard. The base aerial 110 may be shaped to the desk, floor mat or the like. For example, for an "L" or "U" shaped desk, the base aerial 110 may be extended around the corners and along the length of the desk, or alternatively, an additional loop may be added to the base aerial 110.

The base aerial 110 is, preferably, an air core, rectangular loop aerial with a length substantially greater than the width. For telephone headsets, the "very near field effects" of the rectangular loop can be realized if the length of the base aerial 110 is approximately ten times the width of the base aerial 110, and the height of the base aerial 110 is approximately ten times the depth of the base aerial 110.

The remote unit 104 includes a remote transceiver 112 and a remote aerial 114. The remote aerial 114 generates the second magnetic induction field for communicating data from the remote unit 104 to the base unit 102 and receives the first magnetic induction field from the base aerial 110.

For an aerial where the Biot-Savart law applies (i.e. a quasi static field away from a conductive medium), several important observations are made. First, if the distance between two aeriels is much less than the length of the aeriels, the strength of the magnetic field generated between the aeriels varies linearly with distance. Second, when the distance between two aeriels is comparable to the lengths of the aeriels, the strength of the magnetic field falls off inversely with the square of the distance. Lastly, when the distance between the aeriels is significantly longer than the lengths of the aeriels, the strength of the magnetic field falls off inversely with the cube of the distance. Thus, by adjusting the aerial dimensions and/or adjusting the driving current supplied by a transceiver, the aerial footprints (i.e., the area defined by a line of equipotential having a field strength indicative of the operation of the system), can be controlled. By controlling the shape of the aerial footprint, closer spacing of remote units in a multiple-user environment can be achieved, thus reducing the demand on frequency spectrum allocation.

It is noted that the precise decay law is also frequency dependent, especially for distances much larger than the aerial dimensions. The above-description, however, is sufficient to describe the nature and the benefits of the invention.

For example, assume that the base aerial 110 lies parallel to the front of a desk. As the user moves along the front of the desk, the user moves parallel to the long axis of the base aerial 110 and remains in a magnetic inductive field of substantially constant strength. The quality of the communication over the link is maintained in this dimension by extending the length of the rectangular loop of the base aerial 110. Alternatively, the base aerial 110 is a single loop air core conductor that may be shaped to conform to a workstation and integrated with the workstation, or a desk on which the work station rests. This embodiment allows the range of the aerial to be extended without increasing the drive power from the base transceiver 106.

Referring to FIG. 2, there is shown a block diagram illustrating one embodiment of the aerial interface 108 and the base aerial 110 of the communication system 100. The aerial interface 108 includes a drive coil 202 and a permeable core 204. The base aerial 110 includes rods 206 and

blocks 208. The drive coil 202, permeable core 204, and base aerial 110 constitute a transformer with a short-circuited, single-turn secondary. The drive coil 202 may be disposed adjacent a drive module (not shown) in the aerial interface 108 or may be disposed remote from the drive module and connected by a cable (not shown). The drive coil 202 receives a current containing the data to be communicated from the base transceiver 106 and generates a field which is inductively coupled through the permeable core 204 to the base aerial 110. One embodiment of the base aerial 110 may be constructed with, for example, rods 206 formed from conductive material, such as aluminum, which are inserted into holes in blocks 208 also formed from conductive material, such as aluminum. Alternatively, the base aerial 110 may be formed, for example, of self adhesive foil or self adhesive flexible printed circuit board. The shape of the base aerial 110 may be altered to conform with the physical shape of the workstation. By forming the loop of a flexible material, the shape of the loop may be formed at the time of installation.

Referring to FIG. 3, there is shown a side view of one embodiment of a vertical field configuration of aeriels in accordance with the present invention. The configuration includes an air core loop aerial 300 in the base unit 102 and a permeable core solenoid aerial 320 in the remote unit 104. The loop aerial 300 is perpendicular to the view shown and has a major axis in the horizontal plane. The loop aerial 300 generates magnetic flux lines defined by a magnetic flux vector 310 ("H") that extend through the center of the loop aerial 300. Although not shown for simplicity, the magnetic flux lines generated by the loop aerial 300 close on themselves.

The windings of the solenoid aerial 320 are disposed about its longitudinal axis. When the longitudinal axis of the solenoid aerial 320 is parallel to a center axis 330 of the loop aerial 300, the coupling between the solenoid aerial 320 and the loop aerial 300 is maximized. As the longitudinal axis of the solenoid aerial 320 is rotated, the strength of the magnetic coupling between the aeriels approaches zero when the longitudinal axis of the solenoid aerial 320 is perpendicular to the center axis 330 of the loop aerial 300. Similarly, as the solenoid aerial 320 is elevated above or lowered below the plane of the loop aerial 300, the strength of the magnetic coupling between the aeriels is reduced. Such coupling is analogous to a vertically polarized RF system.

Referring to FIG. 4, there is shown a top plan view of the response area, i.e., footprint, for the base unit 102 and the remote unit 104 of FIG. 1. The base unit 102 including a loop aerial 300 has a response area 402 that is elongated. The remote unit 104 including a solenoid aerial 320 has a response area 404 that is circular. As discussed previously, by controlling the shapes of these aerial footprints, closer spacing of remote units in a multiple-user environment can be achieved, thus reducing the demand on frequency spectrum allocation.

Referring to FIG. 5, there is shown a side view of one embodiment of the invention including a transmitting solenoid aerial 500 and a search coil 502. The search coil has a major axis 501 parallel to the longitudinal axis 503 of the solenoid aerial 500. The solenoid aerial 500 has lines 505 joining points of constant induced voltage in the search coil 502 that extend from the solenoid aerial 500 and have peaks in a plane perpendicular to the longitudinal axis of the solenoid aerial 500 and peaks that have a maximum along the longitudinal axis 503 of the solenoid aerial 500. The lines 505 of constant voltage have null lines 506 that are along conical surfaces that are approximately 45 degrees to the

longitudinal axis of the solenoid aerial 500. The solenoid aerial 500 also has magnetic flux lines 507 that extend through the solenoid aerial 500 and close on themselves.

Referring to FIG. 6, there is shown a pair of solenoid aeral 504 having mutual null lines that are approximately aligned. A system that uses the same aerial for transmitting and receiving typically has a complex duplex filter at the receiver input. This complexity, however, may be reduced by employing a pair of parallel solenoid aeral 504, where one aerial is used to transmit and the other aerial is used to receive. The aeral 504 can be used in the remote unit 104 (e.g., headset, body pack). These solenoid aeral 504 are null coupled to provide isolation between the transmit signals and the receive signals, thus preventing interference between aeral. This embodiment eliminates the need for filtering the high level transmit signal that would otherwise couple to the receive aerial.

Referring to FIG. 7, there is shown a side view of one embodiment of a horizontal field configuration of aeral in accordance with the subject matter of the invention. The configuration includes an air core loop aerial 710 in the base unit 102 and a crossed aerial 714 in the remote unit 104. The loop aerial 710 is perpendicular to the view shown and has a central axis 701 in the vertical plane. The loop aerial 710 generates a plurality of magnetic flux lines defined by the magnetic flux vector 702 ("H") that extend through the center of the loop aerial 710. Although not shown for simplicity, the magnetic flux lines generated by the loop aerial 710 close on themselves.

The crossed aerial 714 includes first and second solenoid aeral 716 and 718, which are perpendicular to each other. Specifically, the solenoid aeral 716 and 718 include a ferrite permeable core and loops (not shown) disposed on the permeable core that are perpendicular to the longitudinal axis of the solenoid aeral 716 and 718. When the longitudinal axis of the solenoid aerial 718 is parallel to the center axis 701 of the loop aerial 710 and the solenoid aerial 718 is in the same horizontal plane as the loop aerial 710, the coupling between the solenoid aerial 718 and the loop aerial 710 is maximized. As the solenoid aerial 718 rotates, and thus as the longitudinal axis of the crossed aerial 714 rotates, the strength of the magnetic coupling approaches zero when the longitudinal axis of the solenoid aerial 718 is perpendicular to the center axis 701 of the loop aerial 710. The coupling of the solenoid aerial 716 functions in the reverse direction with the coupling increasing from zero to maximum coupling during the 90 degree rotation. Furthermore, as the solenoid aerial 718 is elevated above or lowered below the plane of the loop aerial 710, the coupling between the solenoid aerial 718 and the loop aerial 710 is reduced. Such coupling of the solenoid aerial 716 is analogous to a horizontally polarized RF system.

The crossed aerial 714 preferably is used in applications in which it is necessary to avoid the nulls of the aerial, which are in a line at about 45 degrees from the major axis by the geometry of FIG. 6, and where it is necessary to avoid the nulls that occur, the null by the mechanism just described if the user rotates, for example, in a swivel chair.

The signals received by the solenoid aeral 716 and 718 preferably are summed vectorally and provided to the remote transceiver 112 of the remote unit 104 in FIG. 1. Alternatively, the remote transceiver 112 of the remote unit 104 may process the signal from the solenoid aeral 716 and 718 having the greatest magnitude.

The crossed aerial 714 receives a signal having a strength that is theoretically twice the strength of the signal received

by the aerial 320 (FIG. 3). By design, the crossed aerial 714 also has twice the sensitivity. Thus, the crossed aerial 714 provides a 12 dB signal advantage over the aerial 320. In some applications, this increased performance would justify the extra complexity of combining the signals from 716 to 718.

In a horizontal magnetic field system as shown in FIGS. 7 and 8, if the range of the fields behind the base unit 102 encroaches an area required by another system, the aerial 710 may be tilted so that the field behind the base unit 102 is directed downward toward the floor to reduce such encroachment.

In a vertical magnetic field system as shown in FIGS. 3 and 4, the base aerial 300 of the base unit 102 may be rotated slightly about the major axis to avoid the geometry described above in conjunction with FIG. 6, such as may occur when the user stands up.

Referring to FIG. 8, there is shown a top plan view illustrating the response area for the base unit 102 including the aerial 710 and the remote unit 104 including the crossed aerial 714. The base unit 102 has a response area 802 that is elongated. The remote unit 104 has a response area 804 that is circular.

Referring to FIGS. 9a and 9b, there is shown a partial perspective view of the fixed aerial array 910 and an exploded view of a mobile aerial array 914, respectively. The fixed aerial array 910 generates a magnetic inductive field having a first orientation (e.g., horizontal) for transmissions and receives a magnetic inductive field having a second orientation (e.g., vertical) that is orthogonal to the first orientation. The fixed aerial array 910 includes a receive aerial 902 having a loop shape, such as described above for the loop aeral 300 and 710 (FIGS. 3 and 7) and having a rectangular transverse cross section. The fixed aerial array 910 also includes a transmit aerial 904 having a loop shape and having a rectangular transverse cross section. The shorter surface of the transmit aerial 904 is disposed on the longer surface of the receive aerial 902 to form a T-shape transverse cross section. The mutual inductance between the receive aerial 902 and the transmit aerial 904 is low, ideally zero. This provides a second, preferred method for isolating transmitted signals from the receiver input and reducing the demands on input filters with associated savings in cost and power consumption.

The mobile aerial array 914 generates a magnetic inductive field having a first orientation (e.g., vertical) for transmissions and receives a magnetic inductive field having a second orientation (e.g., horizontal) that is orthogonal to the first orientation. The mobile aerial array 914 includes a crossed horizontal aerial 916 for receiving and a vertical aerial 918 for transmitting. The cross horizontal aerial 916 includes a first solenoid aerial 920 and a second solenoid aerial 922 perpendicular to the first solenoid 920. The solenoid aeral 920 and 922 are similar to the solenoid aeral 716 and 718 described above in conjunction with FIG. 7. Specifically, the solenoid aeral 920 and 922 include a ferrite permeable core and loops disposed on the ferrite core (not shown). The vertical aerial 918 may be, for example, a solenoid aerial similar to solenoid aeral 920 and 922.

Various embodiments for the remote aerial 114 of the remote unit 104 are now described. In a remote unit that is used as a user telephone headset, the remote aerial 114 preferably is compact and light weight. As a development of the mobile aerial array 914, the remote aerial 114 preferably includes dual or triple axis aeral disposed on a single

permeable core to provide sensitivity and frequency response that is matched for each aerial. A tri-axis aerial may be formed by combining three single axis aerials as in the mobile aerial array 914, a single axis aerial with a dual-axis aerial, or three windings on a single permeable core.

Referring to FIGS. 10a and 10b, there is shown top and side cross-sectional views, respectively, of a dual-axis aerial array 1000 for the remote unit 104 in accordance with one embodiment of the invention. The dual-axis aerial array 1000 includes a permeable core 1002 and first and second windings 1004 and 1006. The permeable core 1002 is box shaped and formed of ferrite. The first winding 1004 is disposed on the surface of the core 1002 in a first plane. The second winding 1006 is disposed in a second plane perpendicular to the first plane. The windings 1004 and 1006 are oriented to minimize mutual inductance. The physical construction of the windings 1004 and 1006 provide this minimization which negates any need for additional mechanical fixing or adjustment, for nulling. In most applications, such a structure is therefore described as self-nulling. The dimensions of the core 1002 are selected so that the windings 1004 and 1006 have substantially identical inductance and capacitance.

Referring to FIGS. 11a-11b, there are shown cross sectional and top plan views, respectively, of a magnetic inductive aerial 1100 in accordance with another embodiment of the present invention. The aerial 1100 includes a permeable core 1102 and first and second windings 1104 and 1106, respectively. The permeable core 1102 is disk-shaped and formed of ferrite. The first and second loops 1104 and 1106 are disposed in respective planes perpendicular to the flat surface of the permeable core 1102 and preferably perpendicular to each other. Flux enters and exits the permeable core 1102 perpendicular to the surface of the core 1102 (not shown). The round surfaces facilitate the capture and routing of flux through the loops 1104 and 1106, which allows the aerial 1100 to function better over angles of rotation of the remote unit 104. The flux in the core 1102 can be algebraically added to provide a similar result to other embodiments that apply vector addition to the outputs of dual-axis aerials. By eliminating the need for vector addition, this embodiment provides the same result as the other embodiments but with less complexity.

Alternatively, the permeable core may be ellipsoid shaped, and the first and second loops may be disposed in respective planes perpendicular to each other. Such a shaped core is less sensitive to rotation about an axis in the major plane.

Referring to FIG. 12, there is shown a top plan view illustrating an aerial array 1200 in accordance with another embodiment of the present invention. The aerial array 1200 reduces the transmitted field and the receive sensitivity of a base unit 102 in an inductive communication system 100 in the area behind the aerial array 1200, and also reduces the field and sensitivity to the sides of the aerial array 1200. Accordingly, this allows units in multi-user communication systems to be spaced closer together to thereby reduce the required spectrum allocation of such systems for a given density of users. While the aerial array 1200 shown in FIG. 12 is configured to operate in a horizontal field (FIG. 7), the aerial array 1200 may also be configured to operate in a vertical field (FIG. 3).

The aerial array 1200 includes a main aerial 1202 and an auxiliary aerial 1204. The main aerial 1202 and the auxiliary aerial 1204 generate first and second magnetic inductive fields, respectively. Each aerial 1202 and 1204 of the aerial

array 1200 preferably is one of the aerial arrays described in FIG. 9, such as the aerial arrays 910 and 914, which includes both transmit and receive aerials. The aerials 1202 and 1204 are preferably air core coils having a length that is significantly greater than the height. For example, the coil may be rectangular with the ratio of length to height at least five to one and a ratio of height to depth in the order of ten to one. The major axis of the aerials 1202 and 1204 are positioned in the horizontal plane and the flux in the center of these aerials is directed horizontally to provide maximum coupling to a horizontal solenoid aerial in the remote unit. The main aerial 1202 is spaced apart from the auxiliary aerial 1204 at a distance at which the sum of the first and second magnetic inductive fields is directional. The auxiliary aerial 1204 is shorter than the main aerial 1202 so that the field from the auxiliary aerial 1204 decays faster than the field from the main aerial 1202.

The auxiliary aerial 1204 is driven in antiphase to the main aerial 1202 to reverse the flux direction from the aerials and to draw in the fields to the sides of the main aerial 1202 and thereby produce a shaped or focused field for the array 1200. The field strength of the summed fields along the central axis A-A is shown as line 1206. Behind the aerial array 1200, the field from the auxiliary aerial 1204 substantially cancels the field from the main aerial 1202. The same configuration may be used as receiving array.

The outputs of the receive windings may be summed in antiphase to produce a null on the main axis behind the aerial array 1200. The relative gain between the two aerials may be varied to move the position of the null. The directed fields reduce interference between proximate systems. The aerial array 1200 may be shaped to conform to the workstation in a manner similar to the base aerial 110 in FIG. 1.

The aerial array 1200 allows the decay versus range profile of the base station 102 to be altered to conform to a desired area with optimal performance in the desired area and with significant reduction in signals outside this area. As the null behind the aerial array 1200 moves further behind the aerial array 1200, the near field increases and the far field decreases.

Referring to FIG. 13a, there is shown a top plan view illustrating the response area for a remote unit 104 and a base unit 102 that includes the aerial array 1200 of FIG. 12. The aerial 1202 has a response area 1302 that is elongated and extends out further in the front of the base unit 102 than the extension in the back of the base unit 102. The aerial 1204 has a response area 1304 that is elongated and that does not extend significantly beyond the aerial 1202 toward the front of the response area 1302. The remote unit 104 has a response area 1306 that is circular.

Referring to FIG. 13b, there is shown a top plan view illustrating the response area of the aerial array 1200 driven in antiphase. The aerial array 1200 provides a cardioid footprint 1302 when the aerials 1202 and 1204 are driven in antiphase. The fields generated from the aerials 1202 and 1204 cancel behind the aerial array 1200.

Referring to FIG. 14, there is a cross-sectional view of one embodiment of a keyboard 1400 including an aerial array 1402 in accordance with the subject matter of the invention.

The keyboard 1400 includes the aerial array 1402, a base plate 1404, and a keypad 1405. The aerial array 1402 is disposed on the top surface of the base plate 1404 and below the keypad 1405. The aerial array 1402 includes a first pair of crossed aerials 1406 and a second pair of crossed aerials 1408. Each crossed aerial pair may be circuit traces disposed on the surface of a pair of printed circuit boards (not shown)

that are orthogonal to each other. Alternatively, the crossed aeri-  
als may be the fixed aerial array 910 in FIG. 9. The array  
1402 may be tilted to direct the fields. Although FIG. 14  
shows the keyboard 1400 as including only an aerial for the  
base unit 102, the keyboard 1400 may include other elements  
of the base unit 102.

Aerial arrays using steered rotating fields will now be  
described. Using steered rotating fields, the communication  
link of the inductive communication system 100 avoids the  
occurrence of orientations that produce zero mutual induc-  
tance or nulls between the fixed and movable aeri-als or aerial  
arrays. This allows common seating arrangement of users  
and provides a system capable of operation in which both  
units may move and have a random relative orientation.

By way of background, voltage is induced in a receiving  
aerial when it experiences a changing flux. The change may  
be produced by varying the magnitude or the direction of the  
incident field. Alternating the magnitude of a flux in a  
sinusoidal manner induces a sinusoidal voltage in the receiv-  
ing aerial. Rotating the incident field at a constant rate will  
also induce a voltage. The frequency of the induced voltage  
is the same as the frequency of rotation of the field, which  
it can be shown is the same frequency as the frequency of the  
sinusoidal feed to the transmit array.

Referring now to FIGS. 15a, 15b, 15c and 15d, there are  
shown side views of the steered rotating field lines of a  
crossed aerial array 1500. The crossed aerial array 1500  
includes a first aerial 1502 and a second aerial 1504, which  
are orthogonal to each other. A drive current is applied to the  
first aerial 1502. A drive current is applied to the second  
aerial 1504 that is 90 degrees phase shifted from the drive  
current applied to the first aerial 1502 and has the same  
waveform, to produce a rotating field.

Referring specifically to FIG. 15a, the drive current  
applied to the first aerial 1502 generates field lines extend-  
ing perpendicular to the first aerial 1502 in the plane of the first  
aerial 1502. A solenoid receiver aerial 1506 only detects the  
vector component of field lines directed along the longitudi-  
nal axis of the solenoid receiver aerial 1506. Accordingly,  
a solenoid receiver aerial 1506 aligned with the field lines  
detects the maximum signal.

Referring specifically to FIG. 15b, the solenoid receiver  
aerial 1506 is rotated 90 degrees relative to the orientation  
of FIG. 15a. The solenoid receiver aerial 1506 is aligned  
perpendicular to the field lines and detects the minimum  
signal from the first aerial 1502. If no current is applied to  
the second aerial 1504, the solenoid in this orientation is in  
a null of the first aerial 1502. If the second aerial 1504 were  
driven instead of the first aerial 1502, then the second aerial  
1504 would experience maximum coupling to the field. The  
drive current applied to the second aerial 1504 generates  
field lines extending perpendicular to the second aerial 1504  
in the plane of the second aerial 1504.

For a static field and with the orientation shown in FIG.  
15b, the solenoid receiver aerial 1506 is in a null. On the  
other hand, for a rotating field, the aerial 1506 is in a null at  
one time, but has maximum coupling at another time so that  
voltage is induced in the receiver aerial 1506. A single axis  
aerial in the plane of rotation of a rotating field does not  
experience nulls.

Referring specifically to FIG. 15c, the drive current  
applied to the second aerial 1504 generates field lines  
extending perpendicular to the second aerial 1504 in the  
plane of the second aerial 1504. A solenoid receiver aerial  
1506 (not shown) oriented as in FIG. 15b is aligned with the  
field lines and detects the maximum signal. Conversely, a

solenoid receiver aerial 1506 (not shown) oriented as in FIG.  
15a is not aligned with the field lines and detects the  
minimum signal.

Referring specifically to FIG. 15d, if two alternating  
signals are provided in phase to the orthogonal aeri-als, the  
resultant field is the vector sum of the fields generated by  
each aerial and has a direction that is changeable by modu-  
lating the amplitudes of the fields.

Therefore, in a tri-axis aerial, feeding two windings of the  
tri-axis aerial creates a rotating field in the horizontal plane  
as described above in FIGS. 15a and 15b and feeding the  
third winding with a signal in-phase with one of the two  
aeri-als to keep the sum of the signals constant. This causes  
the plane of the rotating field to tilt.

Referring to FIG. 16, there is shown a side view of a  
vertical rotating field communication link 1600 in accord-  
ance with the present invention. The vertical rotating field  
communication link 1600 includes a receive aerial 1602 in  
the base unit 102 and a crossed transmit aerial 1604 in the  
remote unit 104. The crossed transmit aerial 1604 provides  
a rotating field that rotates in the vertical plane as shown in  
FIG. 16. Such an aerial 1604 eliminates nulls from vertical  
displacement in the plane of the transmit and receive aeri-als.  
Accordingly, movement in a vertical direction, such as when  
a user stands up, or if the base unit 102 is on a desk and the  
user wears the remote unit 104 at chest height, does not  
cause the remote unit 104 to encounter a null. Thus, the  
vertical rotating field communication link 1600 provides an  
advantage over a vertical field system that lacks rotating  
fields, which avoids nulls in the horizontal plane but has the  
vertical displacement null problem.

Referring to FIG. 17, there is shown a top plan view of  
one embodiment of a horizontal rotating field communica-  
tion link 1700 in accordance with the subject matter of the  
invention. The base unit 102 includes a crossed field aerial  
1702. The remote unit 104 includes a single receive aerial  
1704. The crossed field aerial 1702 includes a first aerial  
1706 and a second aerial 1708 that is positioned perpen-  
dicular to the first aerial 1706. The cross field aerial 1702  
provides a rotating magnetic field. By increasing the com-  
plexity and bulk of the base unit aerial in the base unit 102,  
the receive aerial in the remote unit 104 may be more  
compact and avoids the occurrence of nulls.

Referring to FIG. 18, there is shown a top plan view of a  
communication cluster system 1800 in accordance with the  
present invention. The communication cluster system 1800  
includes a base unit 1801, a plurality of remote units 104,  
and a monitoring remote unit 1810. The base unit 1801  
includes a central transmitter 1802 and a plurality of local  
receive aeri-als 1804. The central transmitter 1802 provides  
a first plurality of magnetic inductive fields over a first  
region 1806 adjacent the central transmitter 1802 to the  
remote units 104. Each of the first plurality of magnetic  
inductive fields preferably is a rotating horizontal field. Each  
field is generated at a different frequency and each remote is  
tuned to one appropriate frequency.

Each local receive aerial 1804 receives a magnetic induc-  
tive field from a remote unit 104 in a second region 1808  
adjacent such local receive aerial 1804. In one preferred  
embodiment, the local receive aerial array 1804 receives  
magnetic inductive fields that are rotating vertical fields.  
Each second region 1808 may be smaller than the first region  
1806. Each local receive aerial 1804 may have a directional  
footprint to increase performance in sensitivity and rejection  
of adjacent user signals. Each local receive aerial 1804 is  
located in an area adjacent a corresponding user. Such



locations reduce the power required by the remote unit 104 to extend battery life of the remote unit 104 and to reduce interference between adjacent users.

The central transmitter 1802 includes, in a transmission designated for a remote unit 104, a code uniquely identifying such remote unit 104 in the first plurality of magnetic inductive fields.

The remote unit 104 transmits a field in a vertical plane and receives on a horizontal aerial. With this field orientation, the remote unit 104 in combination with the base unit 1801, which transmits a rotating horizontal field and receives on a vertical field, provide the user with freedom of movement around the communication cluster system 1800. The transmit and receive fields of the base unit 1801 and the remote unit 104 are decoupled.

The central transmitter 1802 simultaneously transmits the data to the remote units 104 in the first region 1806. Thus, all signals to the remote units 104 are available in the first region 1806. The communication with the plurality of user remote units 104 and the communication with the monitoring remote unit 1810 are each in a different frequency band. One of the plurality of local receive aerials 1804 communicates with corresponding user remote units 104 in the second region 1808 adjacent said one of the plurality of local receive aerials 1804 and selectively communicates with user remote units 104 with the monitoring remote unit 1810 in a second region 1808 adjacent any of the plurality of local receive aerials 1804. A supervisor may use the monitoring remote unit 1810 to selectively listen to the conversations of any operator while the supervisor is anywhere in the first region 1806 adjacent to the transmitter 1802. The supervisor may selectively monitor all communication made by the communication system 1800 without having to move to any particular portion of the first region 1806.

Referring to FIGS. 19a and 19b, there are shown views of a transmit aerial 1902 and a receive aerial 1904, respectively, of a solenoid array 1900. The transmit aerial 1902 includes first and second windings 1906 and 1908 disposed on the surface of a cylindrical core 1910. The first and second windings 1906 and 1908 are disposed in orthogonal planes that intersect along a longitudinal axis of the core 1910. The receive aerial 1904 includes a winding 1912 disposed along the surface of the core 1910 so that the central axis of the winding 1912 is substantially along the longitudinal axis of the core 1910. This provides a receive aerial 1904 that is orthogonal to the transmit aerial 1902 to minimize mutual coupling.

Referring to FIG. 20, there is shown a diagram illustrating the geometry and tilting of a plane of rotation, respectively, of a tri-axial transmitting antenna 2000, which includes a first winding 2002, a second winding 2004, a third winding 2006, and a core 2008. Also, there is shown a remote unit 2014 including a receive aerial 2016.

The windings 2002, 2004, and 2006 are disposed in orthogonal planes on the surface of the core 2008. The tri-axial transmitting antenna 2000 generates a rotating field that is swept through all possible planes. The tri-axial transmitting antenna 2000 scans in space rather than frequency for the presence of a remote unit 2014 within the range of the tri-axial transmitting antenna 2000. As described above in conjunction with FIG. 15, the plane of the field may be tilted by applying current to the windings 2002, 2004, and 2006 in phase relative to each other. If driven with currents of equal amplitude and 90 degrees relative phase shift, the first windings 2002 and the second winding 2004 produce a field that rotates horizontally in a

plane 2010 of the third winding 2006. If an increasing percentage of the current in the first winding 2002 is applied to the third winding 2006, such that the sum of the fields generated from aeri- als is constant, the plane of rotation is tilted until, when all the current is applied to the third winding 2006 and the current applied to the first winding 2002 is zero, the field rotates vertically in a plane 2012 of the first winding 2002. As shown in FIG. 20, the tilting of the plane is around an axis 2014 lying in a plane of the third winding 2006 linking the points where the first winding 2002 and the third winding 2006 intersect in such plane.

If the current is now progressively reapplied to the first winding 2002, but with reversed polarity, the plane of rotation continues in the same angular direction until the plane is once again horizontal, but having an opposite direction of rotation as the initial condition described above. The 180 degree amplitude modulation of the current applied to the first winding 2002 and the second winding 2006 causes the plane of rotation to sweep out a complete 360 degree volume of rotation.

For a receive aerial 2016 that is a dual-axis receive aerial, the remote unit 2014 may detect the plane of the received signal and then communicate back to the base unit 102. The base unit 102 may then tilt the plane of its field to maintain optimal coupling between the units. This eliminates the potential for vertical or rotational movement to create nulls in the response and also facilitates a power management system, such as the system 2000 described above, by minimizing transmission path losses.

If the receive aerial 2016 is a solenoid receiving aerial, the solenoid receiving aerial is oriented, during the sweeping process of the transmitting aerial 2000, with its longitudinal axis toward the center of the transmitting aerial 2000 for maximum coupling to the transmitted signal.

In one embodiment, the remote unit 2014 remains in a passive receive only mode until the remote unit 2014 detects a search signal from the base unit 102. In this mode, the remote unit 2014 conserves power, which reduces power requirements and thus battery size. As the base unit 102 cycles through a scanning routine, at some time the transmitted signal achieves maximum coupling with the remote unit 2014. At such time, the plane of rotation is aligned with the remote unit 2014.

Referring to FIGS. 21a-21c, there is shown a wireless communication system that automatically aligns a magnetic induction field to establish a two-way communication link between a stationary base unit located, for example, at a user's work station, and a remote unit worn by the user, for example, as a headset or body pack. As the user moves within their work area, a first aerial in the base unit and a second aerial in the remote unit can assume an arbitrary relative orientation to each other. The base unit senses this orientation, then aligns the magnetic induction field to maintain an optimum coupling between the first aerial and the second aerial in the base unit and the remote unit, respectively.

The complexity of duplex filtering is reduced by arranging aeri- als in the base unit and the remote unit to have zero mutual inductance rather than build conventional duplex filters which can be bulky at the frequencies used for MI. While the remote unit preferably uses a simple aerial (e.g., single-axis aerial), the base unit includes a multi-axis aerial because it is responsible for maintaining the integrity of the communication link by automatically aligning the magnetic induction field for establishing or maintaining a two-way communication link with the remote unit.

In FIGS. 21a-21c, a vector measuring MI system 2100 preferably includes a remote unit 102 having a single-axis aerial 2102 and a base unit 104 having a multi-axis aerial array 2104. The single-axis aerial 2102 preferably transmits a quasi-static field from a single winding wound on a permeable core. Alternatively, the remote unit 104 includes a dual-axis aerial as previously described in conjunction with FIGS. 10 and 11.

The multi-axis aerial array 2104 of the base unit 102 preferably is a tri-axial aerial array having three mutually orthogonal windings as previously described in conjunction with FIGS. 9 and 20.

The single-axis aerial 2102 of the remote unit 104 generates a plurality of magnetic flux lines that follow a received flux path 2106 that passes through the multi-axis aerial array 2104 of the base unit 102. The received flux path 2106 is defined by a direction vector 2108 in a three-dimensional space. The three mutually orthogonal windings in the multi-axis aerial array 2104 measure the three components of the direction vector 2108.

More particularly, when the magnetic flux lines pass through the multi-axis aerial array 2104, a voltage is induced in each winding. The voltage in each winding is a measure of a component of the direction vector 2108 defining an orientation of the first magnetic induction field along the longitudinal axis of that winding. A selector module 2220 (FIG. 22b) is coupled to the windings and selects one or more of the windings for transmitting a signal back to the remote unit 104. The selection of the winding is based on the magnitude of the induced voltage in each of the windings.

The selector module 2220 is further coupled to a drive module 2222 (FIG. 22b). The drive module 2222 arranges a drive to each selected winding to be in proportion with the voltage in that winding for generating a second magnetic induction field that is substantially aligned with the first magnetic induction field. This second field establishes a two-way (i.e., duplex) MI link with the single-axis aerial 2102 in the remote unit 104, thus allowing communication signals to be transmitted back to the remote unit 104.

Alternatively, signals sent from the base unit 102 are transmitted via a first set of windings that are co-axial to a second set of windings used for receiving signals from the remote unit 104.

Referring to FIG. 21c, there is shown an optimum coupling between the first aerial of the base unit 102 and the second aerial of the remote unit 104. Under other relative orientations, the received signal in the base unit 102 may be reduced to approximately half that achieved under these ideal conditions.

Referring to FIG. 22a, there is shown one embodiment of a "crossed field" system 2200 that uses rotational fields as described in conjunction with FIGS. 15 and 20. The "crossed field" system 2200 preferably includes a dual-axis aerial array 2202 in the remote unit 104 and a multi-axis aerial array 2204 in the base unit 102. The dual-axis aerial array 2202 includes single-axis aeri- als 2206 and 2208. The multi-axis aerial array 2204 preferably includes three orthogonal windings, 2210, 2212, and 2214 disposed about a spherical, permeable core. The dual-axis aerial array 2202 sends and receives on mutually orthogonal windings disposed about single-axis aeri- als 2206 and 2208, respectively (not shown). When the dual-axis aerial array 2202 transmits a first magnetic induction field, voltages are induced in the orthogonal windings in the multi-axis aerial array 2204 that correspond to the components of a direction vector 2216 defining the orientation of the first magnetic induction field

relative to the multi-axis aerial array 2204 in the base unit 102, as previously described in accordance with FIGS. 21a-21c. The selector module 2220 in the base unit 102 selects one or more windings for transmitting back to the remote unit 104 based on the magnitude of the voltages induced in the windings. Upon selection of those windings for transmitting back to the remote unit 104, a drive proportional to the received signal is applied by the drive module 2222 to the selected winding or windings to generate the second flux path for establishing the communication link with the remote unit 104.

Alternatively, signals sent from the base unit 102 are transmitted via a first set of windings that are co-axial to a second set of windings used for receiving signals from the remote unit 104.

Furthermore, in the "crossed field" system 2200, the multi-axis aerial array 2204 transmits in a direction orthogonal to the direction vector 2216. All directions perpendicular to the direction vector 2216 lie in the plane 2218 orthogonal to the direction vector 2216, so the second magnetic induction field transmitted from the base unit 102 must sweep the plane 2218. This requirement is met by transmitting a rotating field, as previously described, orthogonal to the direction vector 2216.

Referring to FIG. 22b, there is shown one embodiment of a selector module 2220 and a drive module 2222 in accordance with the present invention. The selector module 2220 has a plurality of inputs and outputs. The inputs are coupled to mutually orthogonal windings 2221 for receiving first signals induced in the windings 2221 by the first magnetic induction field and the outputs are coupled to a drive module 2222 for producing second signals in the windings 2221, proportional to the first signals, for generating the second magnetic induction field.

The drive module 2222 has a plurality of inputs and outputs. The inputs are coupled to the outputs of the selector module 2220 for receiving selected first signals and the outputs are coupled to the windings 2221 for transmitting second signals.

In one embodiment of the present invention, the longitudinal axis of the one of the mutually orthogonal windings 2221 with the strongest received signal is selected by the selector module 2220 with, for example, a voltage comparator circuit that compares the magnitude of the voltages induced in each winding and then selects the winding with the highest voltage as an approximation to the direction vector 2116. Once the appropriate winding is selected by the comparator circuit, the voltage of the selected winding is coupled to the drive module 2222 using conventional switching techniques such as, for example, an electronic relay switch. The drive module 2222 then generates a voltage proportional to the received voltage in the selected windings for establishing the second magnetic induction field that is substantially aligned with the first magnetic induction field for maintaining a two-way communication link between the base unit 102 and the remote unit 104.

Aerial arrays that are made in accordance with the present invention maintain a MI duplex link between a base unit and a remote unit having a relative orientation to each other that changes over time as the user moves in their work space. Moreover, the mutually orthogonal relationship between the windings in these aerial arrays results in near zero mutual inductance between such windings, thus reducing or eliminating the need for complex duplex filtering. These aerial arrays provide a simple and inexpensive implementation.

Referring again to FIG. 20, another embodiment in accordance with the present invention is described, wherein the

remote unit 2014 remains in a passive "receive only" mode and detects a search signal from the base unit 102. In this mode, the remote unit 2014 conserves power, which reduces power requirements and thus battery size.

As the base unit 102 cycles through a scanning routine, at some time the transmitted signal achieves maximum coupling with the remote unit. The remote unit 2014 transmits a carrier in the direction of the base unit 102 to indicate the presence of the remote unit 2014 to the base unit 102. The remote unit 2014 also may transmit a signal indicative of the received signal strength (RSS). In response to the RSS signal, the base unit 102 performs a peak detect and locks the plane of rotation at the appropriate angle. The RSS signal is a signal extracted in most receiver designs to operate audio squelch. The RSS signal may be transmitted by a sub-audio tone. The base unit 102 may also use the RSS signal to set the power level of the signal to optimize battery usage by the remote unit 2014. Alternatively, instead of locking on the RSS signal, the base unit 102 may process the transmitted signal from the remote unit 2014 as three vectors and redirect the transmitted signal from the base unit 102 in response to such vectors.

Once the lock is established, audio information may be transmitted on the same frequencies. This is sufficient when there is little movement between the base unit 102 and the remote unit 2014, such as between two portable appliances such as a computer and a printer. On the other hand, if there is frequent movement between the base unit 102 and the remote unit 2014, audio information is preferably communicated on other frequencies so the scanning and locking may occur during such movement and simultaneously with such communication. For example, such communication may occur between a remote unit in an audio headset and a base unit at a workstation or in a briefcase in a portable telephone system. Such a system allows the user to walk about in an area around the base unit.

Referring to FIGS. 23a, 23b, and 23c, there are shown cross-sectional views of a tri-axial transmitting antenna array 2300 along orthogonal planes in accordance with the present invention. The tri-axial transmitting antenna array 2300 couples to the remote transceiver 112 (FIG. 1) to receive driving currents that are phase appropriately as described above in accordance with FIG. 20. The tri-axial transmitting antenna array 2300 includes a permeable core 2301, an X loop 2312, a Y loop 2310, and a Z loop 2308. Each loop 2308, 2310, 2312 is oriented at an angle relative to the other loops. The loops 2308, 2310, 2312 are of substantially identical geometry and cross sections. Likewise, the loops 2308, 2310, 2312 have substantially matching inductance, resistance, and capacitance. The core 2301 is preferably spherical. The core 2301 includes grooves 2302, 2304, and 2306 disposed on the surface. The loops 2308, 2310, 2312 are disposed within the grooves 2302, 2304, and 2306.

FIGS. 23a, 23b, and 23c show views of the array 2300 towards an X plane, a Z plane, and a Y plane, respectively. Concentric circles 2314, 2316, and 2318 are zones through which the loops 2308, 2310, 2312 pass. The X loop 2312 is disposed first and thus is inside the loops 2310 and 2312. The Y loop 2310 is disposed second, and thus is inside the Z loop 2308 and outside the X loop 2312. The Z loop 2308 is disposed third, and thus is outside both the X loop 2312 and the Y loop 2310.

The base transceiver 106 provides first, second, and third signals to the loops 2308, 2310, and 2312, respectively, to generate a magnetic field and to alter the direction of the

magnetic field as described above. The base transceiver 106 may alter the direction of the magnetic field to a direction of a remote unit 104 in response to an RSS signal from the remote unit 104. The RSS signal is a carrier. The remote unit 104 alters the direction of the signal from the base unit 102 in response to the magnetic field.

The base transceiver 106 includes a scan signal in the magnetic field and the remote unit 104 provides the RSS signal at a frequency different than the frequency of the scan signal, and at a frequency different than the frequency of the first, second, and third signals.

Referring to FIG. 24, there is shown a schematic diagram illustrating a conventional pre-amplifier 2400 for an inductive receiver. The conventional pre-amplifier 2400 includes an operational amplifier 2402, a load resistor 2406, an inductor 2408, a first diode 2410 and a second diode 2412, and first and second feedback resistors 2414 and 2416. The load resistor 2406 and the inductor 2408 are shown coupled in "parallel," but an equivalent "series" pre-amplifier may be formed.

Referring to FIG. 25, there is shown a graph illustrating the frequency response of the conventional pre-amplifier 2400. A solid line 2502 and a first dashed line 2504, a second dashed line 2506, and a third dashed line 2508 show the frequency response of the conventional pre-amplifier 2400 for varying resistance of the load resistor 2406. Stray capacitance on the coil creates a resonance in the frequency response. The difference between a low frequency (LF) induction aerial and a radio frequency (RF) aerial is the degree of separation between the normal operating frequency and the self resonant frequency of the aerial. An RF coil operates to a frequency  $f_1$ , typically a few MHz, but well away from self resonance. In contrast, an LP induction coil operates to a frequency  $f_2$ , typically tens of kHz, but close to self resonance.

At low frequencies (typically of the order of  $f_1$ ), the coil functions as a linear inductor, and the frequency response of the coil is substantially linear up to a frequency of approximately frequency  $f_1$ . The output voltage obeys Faraday's Law and is proportional to frequency. RF coils having comparatively few turns on a ferrite core, operate as substantially ideal inductors and usually operate in this frequency range. The operating frequency is typically a few percent of the resonant frequency.

In contrast, low frequency coils usually include many turns to generate an adequate voltage within a volume reasonable for a communication link. Such low frequency coils typically include a multi-layer winding. Because of a significant mutual capacitance between these layers, the frequency response has a resonance,  $f_2$ , that is significantly closer to the operating frequency of the system. An inductive aerial typically operates at a frequency up to about 80 percent of the resonant frequency.

At frequencies above the resonance frequency, the impedance of the aerial is capacitive. At such frequencies, the aerial responds to an electric field component of environmental signals, which in this system is a source of interference. The frequencies at which this occurs is near the operating frequency of the system, and thus these frequencies are within the bandwidth of the frequency shaping pre-amplifier and the receiver of the present invention. The inductive aerial may include an electrostatic shield (not shown) to reduce the electric field component of environmental systems to thereby reduce interference. An electrostatic shield typically reduces the self-resonant frequency of the aerial.

Referring to FIG. 26, there is shown a graph illustrating the frequency response of the conventional pre-amplifier 2400 with varying resistance of the load resistor 2406. Changing the resistance of the load resistor 2406 changes the frequency response of the system. Decreasing the resistance of the load resistor 2406 reduces the Q of the resonant peak. If the load resistance is reduced to the level where its admittance dominates the capacitance of the coil, the system has a frequency response of an L-R circuit instead of an L-C-R circuit.

Such a technique has been used in cable locators to obtain operation at discrete widely spaced frequencies, as indicated by  $f_1$  and  $f_2$  in FIG. 26, from a single aerial. This is advantageous in that an alternative implementation with a high self resonant frequency and the same sensitivity at the frequency  $f_2$  has a reduced frequency at the frequency  $f_1$ . However, such a technique has not been applied in the communication links described herein because the alternative implementation produces a smaller lighter aerial.

The present invention provides a communication link that reduces the amplitude variation across the bandwidth. The frequency response shown in line 2601 includes a region in which the second time derivative of the voltage is less than zero and a region in which the voltage is approximately constant. The present invention uses the high frequency zone having the approximately constant voltage. A high sensitivity low resonant frequency inductive aerial operates with a low input impedance amplifier provides a system with wideband FM performance. Alternatively, a preamplifier includes a load resistance that provides similar frequency response characteristics.

Referring to FIG. 27, there is shown a block diagram illustrating a frequency shaping pre-amplifier 2700 in accordance with the present invention. The frequency shaping pre-amplifier 2700 includes an operational amplifier 2702, a first diode 2704 and a second diode 2706, a load resistor 2708, an inductor 2710, a first capacitor 2712 and a second capacitor 2714, and a first feedback control circuit 2716 and a second feedback control circuit 2718. The inductor 2710 represents the receiver aerial.

The first capacitor 2712 and the first feedback control circuit 2716 are coupled in parallel, and further couple a negative input terminal of the operational amplifier 2702 to ground. The second capacitor 2714 and the second feedback control circuit 2718 are coupled in parallel, and further couple a negative input terminal of the operational amplifier 2702 to an output of the operational amplifier 2702. The inductor 2710, the load resistor 2708, and the first diode 2704 and the second diode 2706 are coupled in parallel and couple a positive input terminal of the operational amplifier 2702 to ground. An anode of the diode 2704 is coupled to a cathode of the diode 2706, and a cathode of the diode 2704 is coupled to an anode of the diode 2706. The pre-amplifier 2700 provides a substantially flat frequency response over a range above a given frequency. A preamplifier to the drive of the transmit aerial 110 (FIG. 1) may be implemented for similar frequency characteristics. The frequency response may be linearized by impedance matching and applying the spectral shaping either to the power amplifier or the preamplifier. The frequency shaping of the preamplifier in the receive channel may be implemented as shown in FIGS. 28-30.

Referring to FIG. 28, there is shown a block diagram illustrating a receive circuit 2800 for a receive aerial in accordance with the present invention. The receive circuit 2800 includes a pre-amplifier 2802, a level detector 2804, a

spectral shaping circuit 2806, a filter 2808, a post filtering gain amplifier 2810, a level detector 2812, a demodulator 2814, a signal separation circuit 2816, an audio processor 2818, and a sound transducer 2820.

Referring to FIG. 29, there is shown a block diagram illustrating a receive circuit 2900 for a directional array in accordance with the present invention. The receive circuit 2900 includes a first pre-amplifier 2902 and a second preamplified 2904, a summing circuit 2906, a level detector 2912, a spectral shaping circuit 2910, a demodulator 2914, a signal separation circuit 2916, an audio processor 2918, and a sound transducer 2920.

Referring to FIG. 30, there is shown a block diagram illustrating a receive circuit 3000 for a dual axis aerial in accordance with the present invention. The receive circuit 3000 includes a first pre-amplifier 3002 and a second preamplifier 3004, a vector summing circuit 3006, a level detector 3012, a spectral shaping circuit 3010, a demodulator 3014, a signal separation circuit 3016, an audio processor 3018, and a sound transducer 3020.

What is claimed is:

1. A magnetic inductive communication system that maintains a communication link between a base unit and a remote unit having a relative orientation to each other that changes over time, comprising:

a remote unit having at least one aerial for transmitting a first magnetic induction field and for receiving a second magnetic induction field, and

a base unit including:

a multi-axis aerial array for transmitting the second magnetic induction field and for receiving the first magnetic induction field, the multi-axis aerial array having a plurality of windings, each producing a first signal in response to the first magnetic induction field that represents at least one component of a direction vector defining an orientation of the first magnetic induction field in 3-dimensional space;

a selector module having a plurality of inputs and outputs, the selector module inputs coupled to the windings for selecting at least one of the plurality of windings to transmit the second magnetic induction field along the direction vector; and

a drive module having a plurality of inputs and outputs, the drive module inputs coupled to the selector module outputs for receiving the first signals of the selected windings, the drive module outputs coupled to the windings for generating a second signal in at least one winding, the second signal proportional to the first signal of the winding for generating the second magnetic induction field having substantially the same orientation as the first magnetic induction field.

2. The system of claim 1, wherein the longitudinal axis of the winding receiving the strongest first signal in response to first magnetic induction field is selected by the selector module as an approximation to the direction vector defining the orientation of the first magnetic induction field in 3-dimensional space.

3. The system of claim 1, wherein the second magnetic induction field rotates in a plane substantially orthogonal to the direction vector, and the second magnetic field induces a signal in a first winding in the remote unit that is located proximate to and orthogonal with a second winding.

4. The system of claim 3, wherein the first winding receives the second magnetic induction field and the second winding transmits the first magnetic induction field.

5. The system of claim 3, wherein the windings in the remote unit are mutually orthogonal and wound on a single permeable core to form a dual-axis aerial array.

6. The system of claim 1, wherein the remote unit includes a single winding that receives and transmits the first and second magnetic induction fields, respectively.

7. The system of claim 1, wherein the remote unit includes a single-axis aerial having a first winding for receiving the first magnetic induction field and a second winding, co-axial with the first winding, for transmitting the second magnetic field.

8. The system of claim 1, wherein the remote unit includes two mutually orthogonal solenoid aerials each having a single winding.

9. The system of claim 1, wherein the first magnetic induction field is a quasi-static field.

10. The system of claim 1, wherein the multi-axis aerial array comprises three mutually orthogonal single-axis solenoid aerials each having a single winding.

11. The system of claim 1, wherein the multi-axis aerial array comprises three mutually orthogonal windings wound on a single permeable core.

12. The system of claim 11, wherein the permeable core is spherical.

13. A magnetic inductive communication system that maintains a communication link between a base unit and a remote unit having a relative orientation to each other that changes over time, comprising:

a remote unit including at least one aerial for transmitting a first magnetic induction field and for receiving a second magnetic induction field, and

a base unit including:

a tri-axis aerial array for transmitting the second magnetic induction field and for receiving the first magnetic induction field, the tri-axis aerial array including at least three mutually orthogonal windings disposed about a spherical, permeable core, at least one winding producing a first signal in response to the first magnetic induction field that represents at least one component of a direction vector defining the orientation of the first magnetic induction field in 3-dimensional space;

selector module having a plurality of inputs and outputs, the selector module inputs coupled to the windings for selecting the winding receiving a strongest first signal to transmit the second magnetic induction field along the direction vector; and

a drive module having a plurality of inputs and outputs, the drive module inputs coupled to the selector module outputs for receiving the first signal of the winding having the strongest first signal, the drive module outputs coupled to the windings for generating a second signal in at least one winding, the second signal proportional to the first signal for generating the second magnetic induction field having substantially the same orientation as the first magnetic induction field.

14. A method of maintaining a communication link between a base unit and a remote unit having a relative orientation to each other that changes over time, comprising the steps of:

generating a first magnetic induction field and receiving a second magnetic induction field from at least one aerial in a remote unit;

producing a signal, in at least one aerial in a base unit in response to the first magnetic induction field, that represents at least one component of a direction vector defining an orientation of the first magnetic induction field in 3-dimensional space;

selecting, in response to the produced signal, at least one aerial in the base unit to transmit the second magnetic induction field along the direction vector; and

transmitting the second magnetic induction field from the selected aerial in the base unit, the second magnetic induction field having substantially the same orientation as the first magnetic induction field for establishing the magnetic induction duplex link with the remote unit.

15. The method of claim 14, wherein selecting at least one aerial comprises selecting the aerial in the base unit receiving the strongest signal in response to the first magnetic induction field as an approximation to the direction vector.

16. The method of claim 14, wherein generating from the base unit a second magnetic induction field comprises generating a field that rotates in a plane substantially orthogonal to the direction vector and that induces in the remote unit a signal in a first aerial located proximate to, and orthogonal with, a second aerial for transmitting the first magnetic induction field.

\* \* \* \* \*

# Appendix G

[54] HELICAL ANTENNA FOR SMALL PORTABLE WIRELESS DEVICES

3,523,251 8/1970 Halstead ..... 343/895  
3,781,899 12/1973 Lockwood ..... 343/895  
4,163,981 8/1979 Wilson ..... 343/895

[75] Inventor: Katsumi Naitou, Ehime, Japan

Primary Examiner—William L. Sikes  
Assistant Examiner—Michael C. Wimer  
Attorney, Agent, or Firm—Cushman, Darby & Cushman

[73] Assignee: Nippon Tsushin Densen Company, Ltd., Yahatahama, Japan

[21] Appl. No.: 127,451

[22] Filed: Dec. 2, 1987

[30] Foreign Application Priority Data

Apr. 21, 1987 [JP] Japan ..... 62-060562[U]

[51] Int. Cl.<sup>4</sup> ..... H01Q 1/36

[52] U.S. Cl. .... 343/745; 343/895

[58] Field of Search ..... 343/745, 747, 748, 750, 343/895, 702, 744, 866, 867, 787, 788

[56] References Cited

U.S. PATENT DOCUMENTS

3,474,453 10/1969 Ireland ..... 343/745  
3,487,463 12/1969 Rogers ..... 343/745

[57] ABSTRACT

A helical antenna for use with small portable wireless devices as disclosed which includes a magnetic tuner including a magnet adapted to move in a direction substantially perpendicular to the longitudinal axis of the antenna whereby the impedance of the antenna can be varied greatly by displacement of the magnet only a short distance. The antenna preferably further includes a variable capacitor for reducing any mismatching between the input impedance of the antenna and the characteristic impedance of an associated feeder which can be caused by adjusting the magnetic tuner.

6 Claims, 6 Drawing Sheets

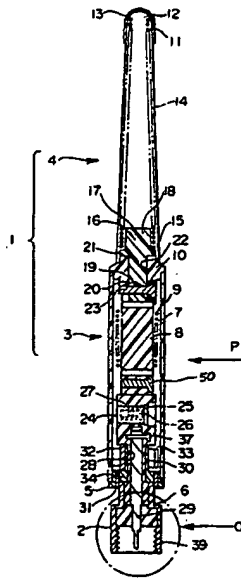

FIG. 1

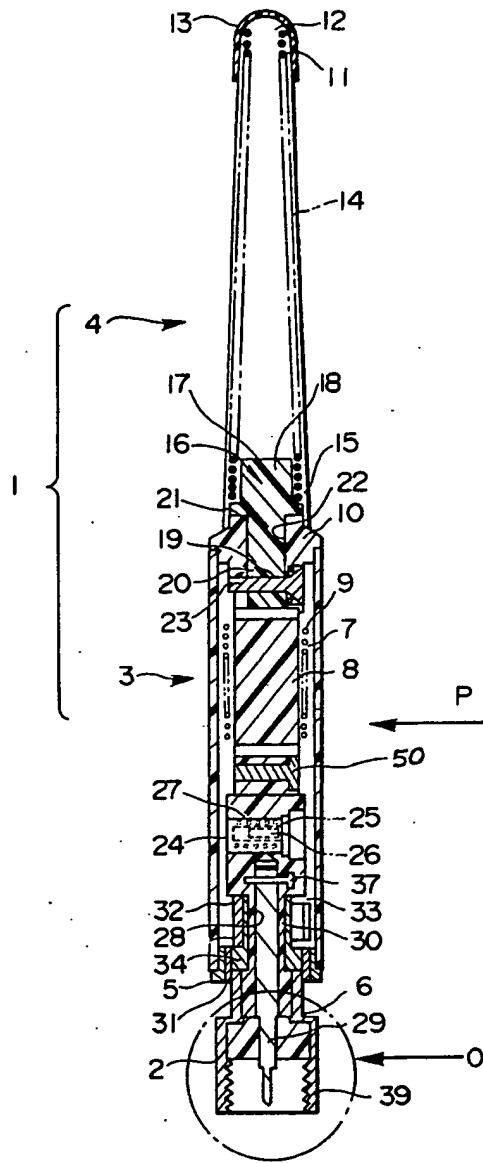



FIG. 2

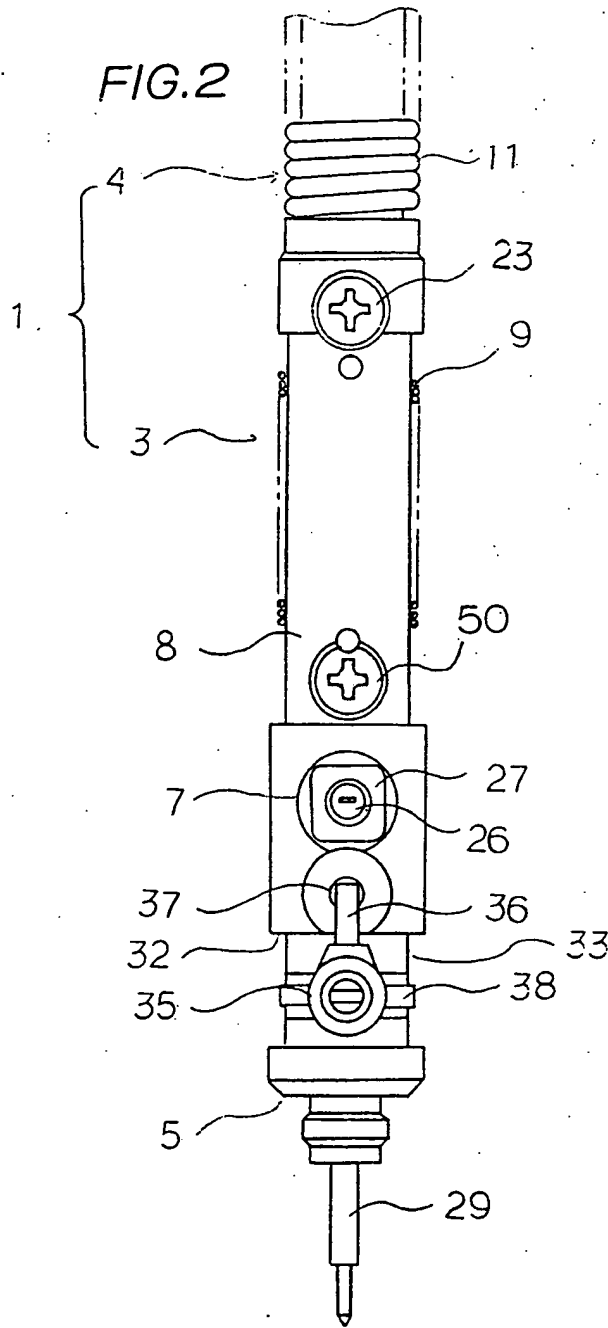

FIG. 3

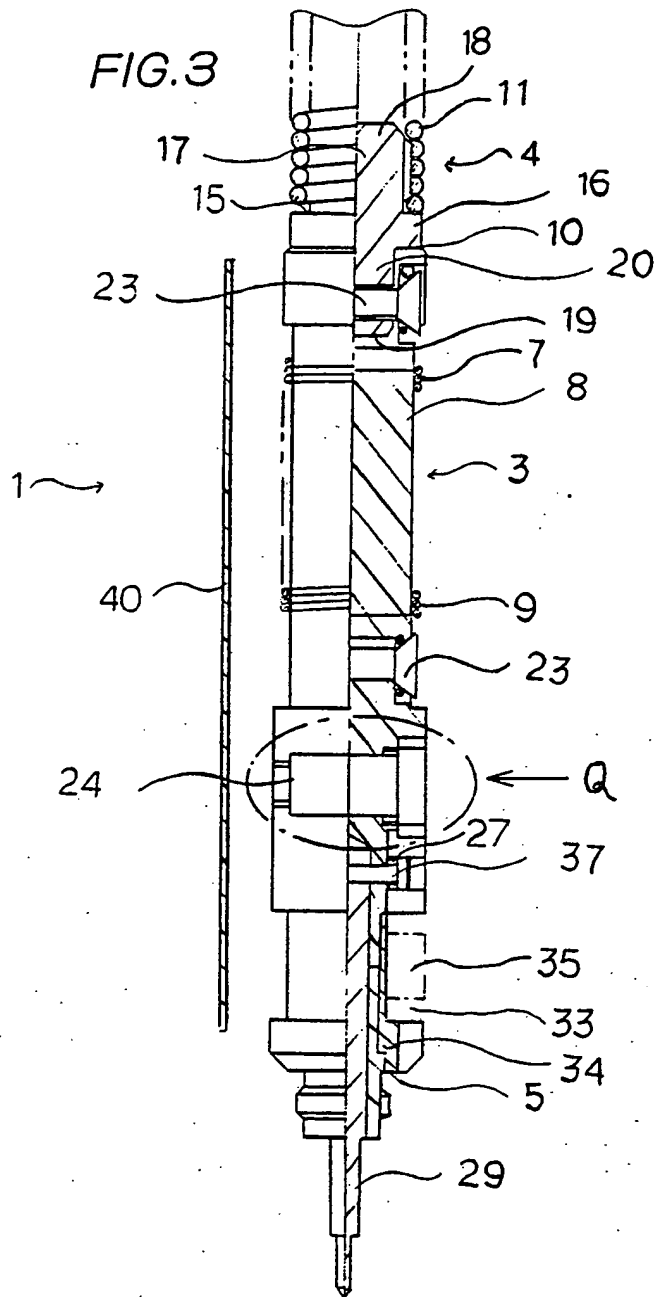

FIG. 4

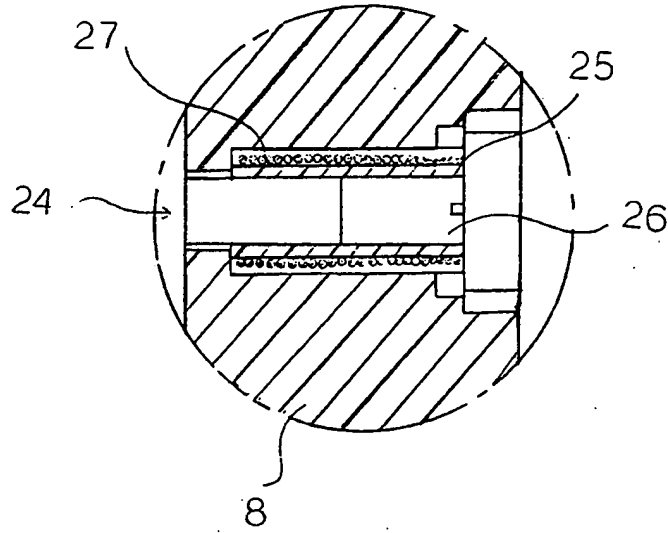

FIG. 5

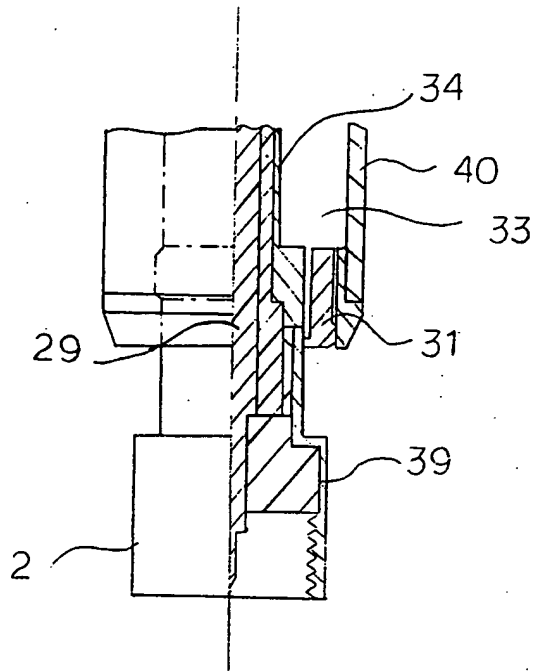
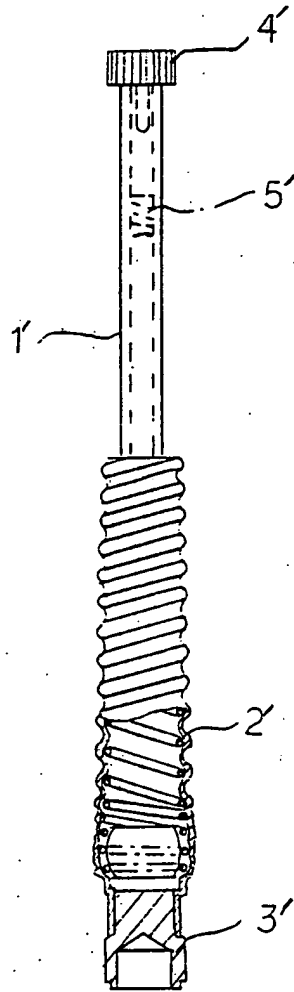

FIG. 6  
(PRIOR ART)



## HELICAL ANTENNA FOR SMALL PORTABLE WIRELESS DEVICES

### BACKGROUND OF THE INVENTION

The present invention relates to helical antennas for portable wireless devices and, more particularly, to a helical antenna including a magnetic tuner for selectively receiving electrical waves of a particular frequency and a capacitance adjuster for reducing any mismatching between the characteristic impedance of an associated antenna feeder and the input impedance of the antenna resultant from varying the inductance of the antenna coil with the magnetic tuner.

Selective reception of a particular frequency among several discrete frequencies is often required for small portable wireless devices. Thus, the antenna or input circuit of a wireless device, for example, is preferably designed so that its inductance can be varied to tune the device into an electromagnetic wave of particular frequency.

In an attempt to meet this demand, conventional small portable wireless devices have been provided with a helical antenna whose inductance may be varied. Such a helical antenna is shown, for example, in FIG. 6. This antenna includes a hollow tube 1' with an antenna element 2' wound thereabout so as to form a coil. The tube 1' has an antenna connector 3' at the bottom end thereof and an antenna cap 4' at its upper end. The antenna further includes a frequency-tuning ferrite magnet 5' which is vertically movably fixed to the inside of the hollow tube 1'. As is apparent, with this arrangement the inductance of the coil can be varied by varying the vertical displacement of the magnet. The tuning ferrite magnet can be moved vertically and will stay at a selected position within the antenna coil. This enables, apparently, the selective reception by the wireless device of an electromagnetic wave of particular frequency.

It has been found, however, that the input impedance of the antenna will vary as the ferrite magnet is moved to vary the inductance of the coil and therefore the input impedance will no longer match the characteristic impedance of the associated feeder which connects the antenna to the wireless device. This resultant mismatching will make it practically impossible for the wireless device to receive the electromagnetic wave selected by tuning the antenna.

Furthermore, the vertical movement of the ferrite magnet in the antenna coil of this prior art device does not cause a substantial variation of inductance because the hollow tube is large in diameter so as to ensure that it is resistive to strong winds and other external forces. More particularly, because the ferrite magnet of this prior art device moves in a large space defined by the hollow tube, there is no appreciable change in inductance even though the ferrite magnet can be moved a relatively long distance along the longitudinal axis of the tube. Accordingly, it has been found that practically no fine tuning is possible with this antenna.

### SUMMARY OF THE INVENTION

In view of the defects of the above-described prior art antenna, it is an object of the present invention to provide a helical antenna for use in small, portable wireless devices which has a magnetic tuner movably mounted in the antenna coil of a tube of relatively small diameter in a direction substantially transverse to the longitudinal

axis of the antenna thereby permitting the input inductance of the antenna coil to vary substantially with displacement of the magnet element of the magnetic tuner in the diammetrical direction of the helical antenna. Thus, it is an object of the present invention to provide a helical antenna which will permit the effective fine tuning of an associated wireless device to an electromagnetic wave of particular frequency.

Another object of the present invention is to provide such a helical antenna including a capacitance varier or adjuster which is adapted to be connected to an associated feeder for reducing any mismatching between the characteristic impedance of the feeder and the input impedance of the helical antenna which can result from the displacement of the magnet element of the magnetic tuner.

Still another object of the present invention is to provide a helical antenna which can keep the standing wave ratio unchanged after a receiving frequency has been selected irrespective of a relatively broad range of selection.

Other objects, features, and characteristics of the present invention, as well as the methods of operation and functions of the related elements of the structure, and the combination of the parts and economies of manufacture, will become more apparent upon consideration of the following detailed description and the appended claims with reference to the accompanying drawings, all of which form a part of this specification, wherein like reference numerals designate corresponding parts in the various figures.

### BRIEF DESCRIPTION OF THE DRAWINGS

FIG. 1 is a longitudinal cross-sectional view of the helical/antenna formed in accordance with the present invention;

FIG. 2 is an enlarged side elevational view taken in the direction "P" of FIG. 1;

FIG. 3 is a side elevational view similar to FIG. 2 but partly in cross-section;

FIG. 4 is an enlarged view of the portion of the antenna indicated as "Q" in FIG. 3;

FIG. 5 is an enlarged view, partly in cross-section, of the portion of the antenna marked with "O" in FIG. 1; and

FIG. 6 is a view partly in cross-section of a conventional helical antenna.

### DETAILED DESCRIPTION OF THE PREFERRED EMBODIMENT

Referring in particular to FIG. 1, the helical antenna formed in accordance with the present invention is shown generally as element 1. The antenna element includes an antenna connector 2, a first antenna sub-element 3 including a wire coil of relatively small diameter, and a second antenna sub-element 4 including a wire coil of relatively large diameter. Antenna element 1 is, for example, about 320 mm long whereas the second antenna sub-element 4 is, for example, about 200 mm long. Antenna connector 2 is fixed to the bottom end 5 of antenna element 1 and the antenna wire coil 7 of antenna sub-element 3 extends from the top of the antenna connector 2. More particularly, an insulating core rod 8 has a winding of wire 9, for example, enamel wire, of a relatively small diameter wound therearound and the core rod 8 is connected to the top 6 of the antenna connector 2.

Antenna sub-element 3 is connected to antenna sub-element 4 which includes a coil of large diameter wire 11, rising from the top 10 of core rod 8. The wire used in the large diameter wire coil is, for example, about 1.5 mm in diameter. A cap 13 is put on the top end 12 of the antenna sub-element 4 and an expandable sheath 14 is applied to antenna sub-element 4.

As can be seen, antenna sub-element 4 gradually decreases in diameter from the bottom end 15 to the top end 12 thereof. The wire 11 itself preferably made of a conductor that is resilient enough to cause the tapering coil to restore to its original position even if a force should be applied to yieldingly bend the same.

An insulating solid 16 including a relatively large diameter section 18, an annular collar 21, and a relatively small diameter section 19 is provided for inter-connecting sub-element 4 and sub-element 3. More particularly, relatively large diameter section 18 is pushed into the bottom end 15 of the tapering wire coil 11 and the relatively small diameter section 19 of the insulating solid is pushed into recess 22 which is provided in the top end of sub-element 3, adjacent to core rod 8. Then, insulating solid 16 is bolted to core rod 8 as, for example, is shown at 23. Coil 7 of sub-element 3 is wound around core rod 8, as set forth above, and is connected to antenna sub-element 4 by the fastener at 23. A magnetic tuner 24 is mounted in the lower portion of core rod 8. The magnetic tuner 24 includes a relatively short hollow cylinder 25 of an insulating material and a ferrite magnet 26 which is movable in hollow cylinder 25. A magnet coil 27 is wound around hollow cylinder 25 and connected to antenna sub-element 3 by a fastener 50. As can be seen, in particular, in FIG. 1, hollow cylinder 25 is mounted so as to have a longitudinal axis which is substantially perpendicular to the longitudinal axis of the antenna element 1 as a whole. Thus, when magnet 26 is moved in cylinder 25, it moves in a direction transverse to the longitudinal axis of antenna 1.

Core rod 8 terminates with a slender hollow extension 30 defining a hollow space 28 which receives a contact pin 29 of antenna connector 2. Contact pin 29 is fixed to core rod 8 by a stopper pin or the like 37 which serves to connect the contact pin 29 to magnet coil 27. Insulator ring 31 formed of, for example, teflon, ABS, etc., is fitted around the lower portion of core rod 8. Thus, an annular recess 33 for accommodating a capacitance adjuster in accordance with the present invention is formed between insulator ring 31 and the transition to the slender extension 30 of core rod 8.

More particularly, the capacitance adjuster or "variable capacitive means" 35 is mounted within annular recess 33 and a variable capacitor metal mount 34 is fixed within the annular recess. Lead wire 36 of the variable capacitance device 35 is connected to stopper pin 37 and hence to the magnetic tuner 24 whereas the other lead wire 38 to the variable capacitive device 35 is connected to metal mount metal 34. Metal mount 34 is in turn coupled to outer sheath conductor 39 of antenna connector 2. When the antenna connector is fitted in the counter antenna connector of a small portable wireless device, the other lead wire 38 of variable capacitive means 35 will be connected to the chassis of the wireless device and, hence, to the ground.

A protective cover 40 of an insulating material is placed on antenna sub-element 3. Protective cover 40 has two holes for permitting access to the magnetic tuner 24 and the variable capacitor 35. If conditions so require, as will be apparent to the ordinary artisan, a

plurality of magnetic tuners and variable capacitors may be used, each allotted two separate divisions of frequency range and marked with numbers representing the division of frequency range for convenience in selecting a desired frequency.

An example in which a helical antenna according to the present invention was used is described below. In this particular example, a helical antenna was used in a small portable wireless device which was designed to handle electromagnetic waves of frequencies ranging from 0 to 10 MHz, specifically, the electromagnetic waves of a plurality of discreet frequencies selected within a broad frequency range. The following description is directed to one of these frequencies.

First, an electromagnetic wave of particular frequency was selected and then the ferrite magnet 26 of magnetic tuner 24 was displaced in the short hollow cylinder 25 in a transverse direction of the helical antenna element 1, thereby varying the input impedance of the helical antenna with the displacement of the ferrite magnet relative to magnet coil 27 wound around hollow cylinder 25 until helical antenna 1 had been tuned to the receiving frequency desired. When this had been accomplished, however, the helical antenna was placed into a mismatched condition with respect to an associated feeder. Thus, the variable capacitor 35 was adjusted to reduce the mismatching between the input impedance of the helical antenna and the antenna feeder which connected the antenna to the wireless device.

As described above, one lead wire of the variable capacitor is connected to the antenna coil and the other lead wire 38 to the variable capacitor connected to the chassis of the wireless device via the antenna connector 2 and the feeder fixed thereto. Accordingly, the adjustment of the variable capacitor caused the characteristic impedance of the feeder to vary.

The above series of steps and resultant adjustment of the device is the same for any other frequencies selected, for example, to realize a best possible receiving condition for the wireless device dependent upon the particular situation, position and other surrounding factors. This feature, then, enables the user to select a most appropriate receiving frequency among a plurality of discreet frequencies in a broad frequency range and to perform the fine tuning to the frequency thus selected.

As described above, ferrite magnet 26 is adapted to move in the hollow cylinder 25 in a direction which is substantially perpendicular to the longitudinal axis of the helical antenna and magnet coil 27 is a dense winding of wire of relatively small diameter. With this arrangement, displacement of the ferrite magnet a very short distance can cause a great change in the input impedance of the antenna. This contributes to the fine adjustment of input impedance. Also, the crosswise arrangement of the tuner 24 permits a substantial reduction of the antenna and system size as a whole. Further, it should be noted that the input impedance of the antenna and the characteristic impedance of the feeder can be exactly matched without changing the standing wave ratio.

While the invention has been described in connection with what is presently considered to be the most practical and preferred embodiment, it is to be understood that the invention is not limited to the disclosed embodiment, but, on the contrary, it is intended to cover various modifications of the preferred arrangements in-

cluded within the spirit and scope of the appended claims.

What is claimed is:

1. A helical antenna having a longitudinal axis and an antenna connector at a first end thereof for coupling to a small portable wireless device, said antenna having a wire coil defined therein and including a magnetic tuning means comprising:

a hollow cylindrical member formed from an insulating material disposed within said helical antenna so as to have a longitudinal axis extending in a direction substantially perpendicular to the longitudinal axis of the helical antenna;

a magnet element disposed within said hollow cylindrical member and movable along the longitudinal axis of said hollow cylindrical member so as to be movable in a direction substantially perpendicular to the longitudinal axis of the helical antenna; and

a wire coil element disposed so as to be wound around said hollow cylindrical member, said wire coil element being electrically coupled to said wire coil of said antenna and to said antenna connector whereby, displacement of said magnet element within said hollow cylindrical member varies the inductance of the antenna so as to selectively tune the antenna to an electromagnetic wave of particular frequency.

2. A helical antenna as in claim 1 wherein said helical antenna further includes a variable capacitance means mounted intermediate said magnetic tuning means and said antenna connector for reducing any mismatching between the characteristic impedance of an antenna feeder of the wireless device and the input impedance of the antenna caused by displacement of said magnet element.

3. A helical antenna as in claim 1, further comprising an antenna sub-element including a core rod of insulating material having a wire coil of a wire of relatively small diameter wound therearound, said wire coil of relatively small diameter being operatively coupled to said magnetic tuning means.

4. A helical antenna as in claim 3, further comprising a second antenna sub-element element including a wire coil of a wire of relatively large diameter and operatively coupled to the first antenna sub-element wire coil and extending upwardly from an upper end of said core rod.

5. A helical antenna as in claim 4, wherein said wire coil of said second antenna sub-element varies in diameter from a largest diameter adjacent said core rod to a smallest diameter at the uppermost end thereto.

6. A helical antenna as in claim 4, further comprising means for interconnecting said first and second antenna sub-elements.

\* \* \* \* \*

30

35

40

45

50

55

60

65